

AMTEC™

HYDRACLAMP

A Division of Higginson Equipment Inc.

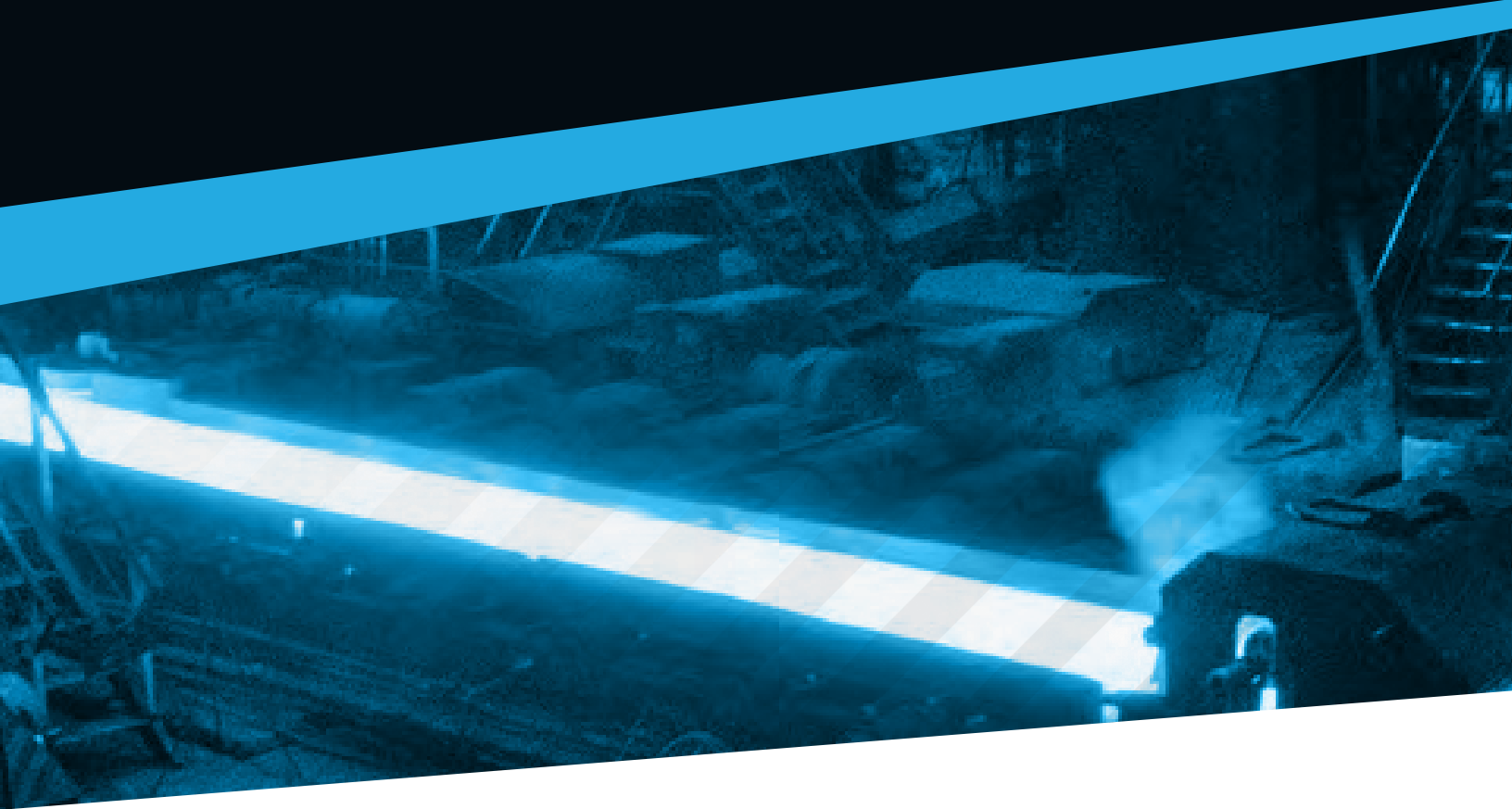

PRODUCT CATALOGUE

Table of Contents

About Amtec	4	H-Nuts	48
The AMTEC Advantage	6	SERIES H-2.4 & H-2.10	50
Threads - ID Section	7	SERIES H-3.4 & H-3.10	51
Industry Applications Guide	8	H-Type Nut Operating Instructions	52
Quick Reference Guide	13	Rapid Shear Knife Change-Over Arrangements with H-049 Type Nuts	54
F-Nuts	14	H-Type Nuts Accessories	56
STANDARD SERIES F-8.4 & F-8.10	16	Step Nuts	58
MAX-FORCE SERIES F-8.4 & F-8.10	17	Block Nuts	60
AIRCRAFT QUALITY ALUMINUM SERIES F-8.4 & F-8.10	18	Grease-Bloc Nuts	62
STANDARD SERIES F-9.4 & F-9.10	19	Clamp Rings	64
MAX-FORCE SERIES F-9.4 & F-9.10	20	Handpumps	66
AIRCRAFT QUALITY ALUMINUM SERIES F-9.4 & F-9.10	21	CHAIN Series Handpumps	66
Spare Parts Replacement Instructions	22	ROD Series Handpumps	68
F-Type Nut Operating Instructions	24	Oil Handpumps	70
F-Type Nut Accessories	26	Mobile Grease	71
K-Nuts	28	Bulk Fill Pumping System	71
STANDARD SERIES K-6.1 & K-6.2	30	Accessories	74
STANDARD SERIES K-7.1, K-7.2 & K-7.4	31	F-Nipple	74
SERIES K-025.XXX.610	32	F-Coupler	75
SERIES K-025.XXX.710	33	Assist Bars	76
Refill Instructions	34	Grease Recommendations	77
Spare Parts Replacement Instructions	35	GX-Couplers & GX-Nipples	78
K-Type Nut Operating Instructions	36	GR-Couplers & GR-Nipples	79
Side Trimmer Nuts	38	Hex Plug for H-Nuts	80
K-Type Nut Accessories	39	R1 Pilot Operated Check Valve	80
GX-Nuts	40	High-Pressure Hoses	80
SERIES GX-4.4 & GX-4.10	42	Hex Wrenches	81
SERIES GX-5.4 & GX-5.10	43	Pressure Transponders	82
GX-Type Nut Operating Instructions	44		
GX-Type Nuts Accessories	47		

About Amtec

Amtec Hydraclamp is the world leader in high-pressure clamping and tensioning solutions, with a worldwide reputation for quality and reliability. Based in Canada, Amtec has decades of experience in the engineering and manufacture of hydraulic nuts, pre-tensioning devices, block nuts, step nuts and related accessories.

Our hydraulic clamping components are designed to withstand severe operating conditions in casters, rolling mills, metal processing and forming lines, presses, turbine and aircraft engine broaching machines, and machine tools.

Amtec Hydraclamp has a wide range of standard hydraulic nut sizes to fit most machine and tool-clamping applications. In addition, our custom-engineering capabilities allow us to address specific clamping or pre-tensioning requirements using grease or oil as a pressure medium.

Amtec Hydraclamp has established a reputation as a leader in the design and engineering of positive pressure-controlled clamping devices used by companies in North America, South America, Europe, China, Japan, United Kingdom, South Korea, India and many other countries.

We sell through worldwide distribution channels, but if your business partners with mostly steel-industry customers in one of our unassigned regions, please get in touch to find out if you qualify for exclusive distribution in your area.

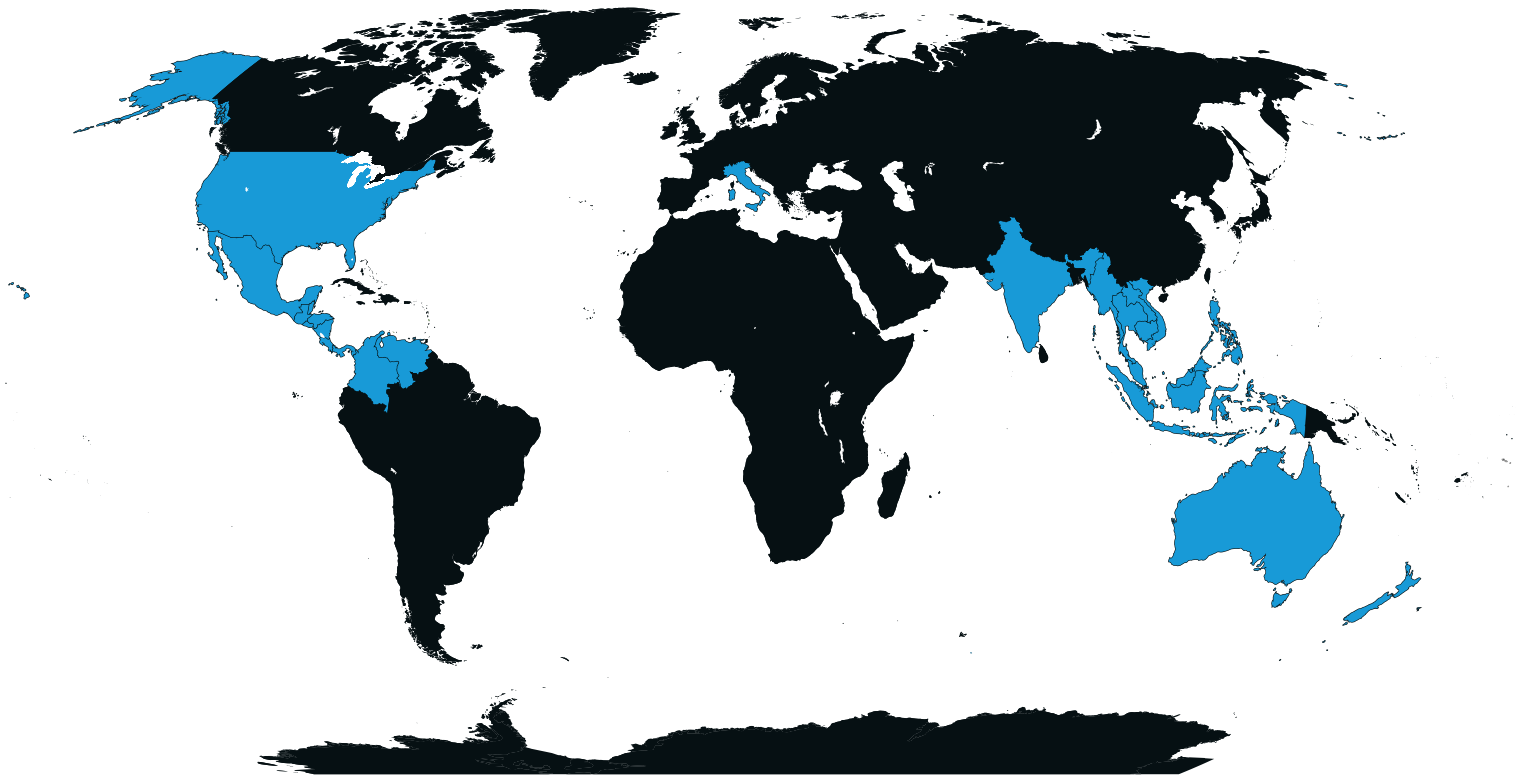

Amtec Hydraclamp and our Distributors

Company name	Address	Territories	Contact Information	Website
Amtec Hydraclamp	1175 Corporate Dr. Unit 1, Burlington, Ontario, Canada, L7L 5V5		+1 (905) 335 2211 info@amtechydraclamp.com	amtechydraclamp.com
Andritz ASKO Inc	501 West Seventh Ave, Homestead, PA, USA, 15120-1036	USA Except: Ohio, Michigan and Indiana	+1 (412) 461 4110 asko.inquiries@andritz.com	askoinc.com
Specialty Grinding Co.	3933 S. Greenbrooke SE, Grand Rapids, MI 49512	Ohio, Michigan and Indiana, USA	+1 (800) 542 0383 sales@specialtygrinding.com	specialtygrinding.com
Adek S.A. de C.V.	Amado Nervo No. 2900 Col. Bellavista, Monterrey Nuevo Leon Mexico. cp 64410	Mexico Belize Guatemala El Salvador Honduras Nicaragua Costa Rica Panama Colombia Venezuela	+52 (81) 8351 2323 ventas@adek.com.mx	adek.com.mx
PICCO S.R.L	Corso Filippo Turati 11/C , 10128 - Torino , Italia	Italy	+39 (011) 1948 1340 info@picco-co.it	http://www.picco-co.it/
Zenith Techpro	316, Swagat Business Hub, Ichhapore, Surat - 394510, Gujarat, India	India	(+91) 93130 20857 sales@zenithtechpro.com	zenithtechpro.com
C.E. Mech Engineering Co., Ltd	128/780 Moo1, Teparak Rd., T. Bangsaothong, A. Gangsaothong, Samutprakarn, 10540 Thailand	Thailand Myanmar Vietnam Laos Cambodia Brunei Singapore Malaysia Philippines Indonesia	+66 81755 6577 kumpoo.w@cemech.co.th	cemech.co.th
Pinard Enterprises Pty Ltd	PO Box 468, Turrumurra, NSW 2074 Australia	Australia New Zealand	+61 2 944 09444 sales@pinard.com.au	pinard.com.au
Bolt-Engineer Co.	255-6, Furasato, Iwaoka-Cho, Nishi-Ku, Kobe Japan 651-2404	Japan	+81-789675720 info@tension-nut.jp	http://www.tension-nut.jp/

The AMTEC Advantage

Amtec Hydraclamp manufactures the world's best high-pressure hydraulic clamps, making Amtec the number one choice for OEM's, steel mills, processing plants, utilities and any other industry requiring reliable, superior clamping technology.

Clamping Advantage

- Up to 500% more clamping force compared to mechanical nuts.
- Larger thrust rings, 4140 alloy steel components, and proprietary dual durometer seals provide superior clamping force in comparison to any competitive hydraulic nut supplier.
- Self-aligning thrust ring provides uniform 360° contact with mating tooling.
- Adjustable pressure Amtec pumps grant controllable clamping force for F-Type & GX-Type Nuts.
- Custom threaded to suit existing international standard specifications.

Reliability & Durability

- 300% longer service life with 4140 steel or aircraft aluminum nut bodies, precision thrust rings and dual durometer seals.
- Sealing system allows up to 3 weeks in-service time without significant pressure drop.
- Amtec's leak proof F-Nipples (for grease) and GX-Nipples (for oil) made from high strength steel bodies with high-pressure check valves to maintain positive pressure retention.
- Precision actuator piston assemblies provide extreme pressure output for K-Type Nuts.
- Thread wear is no longer a problem with proper thread matching and Amtec's special OD-centering.
- Bearing damage from hammering mechanical nuts is eliminated by our easy installation.
- Black-oxide finish prevents oxidation on steel nut bodies (other finishes available).

Safety

- Amtec engineers nuts to exceed operating requirements.
- Hammers and wrenches are not required; only a hex wrench, small assist bar and portable pump. Choice of peripheral or end face access for operator convenience.
- F-Nipples, GX-Nipples, Series 550 Transponder and actuator pistons are fully recessed for protection against physical or mechanical damage.
- Knurled outside diameter for better grip.
- High-strength aircraft aluminum nut bodies offer 50-60% weight reduction vs. steel in F-Type Nuts.

Custom Engineering

- Custom designed devices with integrated pressure control systems and quick disconnect fittings are available.
- Safe, convenient and durable, Amtec pressure control systems have been custom engineered for grease or oil at pressures up to 700 bar (10,150 psi).
- Special seals can be installed for high temperature use.
- Extra corrosion resistance through use of electroless nickel, chrome plating or stainless steel.
- High-pressure hydraulic power units, bulk grease systems and other packages are available.

Threads - ID Section

Amtec can manufacture our hydraulic clamps to accept any thread form or size. Amtec will custom machine threads for every production piece so long as thread diameter is smaller than the physical limitations of the nut.

For industrial use, the most robust and highly recommended thread form is Acme (Imperial) or Trapezoidal (Metric). The 29° included angle Acme or the 30° Trapezoidal provides the largest cross-section and top land area of all thread forms to resist mechanical damage and loading distortion.

We manufacture hydraulic clamping devices with our Amtec Special OD centering thread design. Amtec Special internal threads suit all thread forms with substantial OD land areas; i.e., Acme, Buttress, Trapezoidal. The OD centered feature allows easy rotation by hand for even very heavy clamps. Our Special Threads reduce rotational contact area between the internal and external threads.

Amtec guarantees proper fit only by receiving accurate thread information, which complies with standard international specifications (Machinery's Hand Book or others). Amtec manufactures test bolts to exact standards for verification of thread fit after machining, and maintains a large inventory of test bolts for every thread form, pitch and rotation (hand).

Thread gauges verify thread form and pitch, and micrometers or pi tapes must be used to verify diameters. Variable diameters over a given thread length will indicate wear and may prevent proper fit between external and internal threads.

External thread diameters which vary by 0.5 mm (.02 inches) or more constitute "bastard" threads that can only be properly fitted by hand through a local machine shop. These applications must be considered on a case-by-case basis for best results.

Imperial thread forms are specified in 1/4", 1/8" and 1/16" diametral increments. Metric thread forms are specified in 10, 5 and 2 millimeter diametral increments.

Thread pitch (axial distance between adjacent threads) is specified by threads per inch (TPI) for imperial series and by actual pitch in millimeters (P) for metric series.



Threads in both imperial and metric series may be either right or left hand rotation to tighten. With Amtec Hydraulic Clamping Devices, threads may all be right hand, regardless of shaft/arbor rotation, without risk of unwinding. Our extreme clamp force during operation prevents disengagement, as long as minimum pressure is maintained in the nuts.

Examples of properly detailed thread specifications, including (4) major features are as follows:

- UN 7.000" - 6 TPI RH (60° "V" thread)
 - ▶ UN - Unified National thread form
 - ▶ 7.000" - major thread diameter
 - ▶ 6 - threads per inch
 - ▶ RH - right hand rotation
- ACME 8.500" - 4 TPI LH
- Butt (Buttress) 6.750" - 6 TPI RH
- M (Metric) 160 - 8P RH (60° "V" thread)
- TR (Trapezoidal) 330 - 6P LH

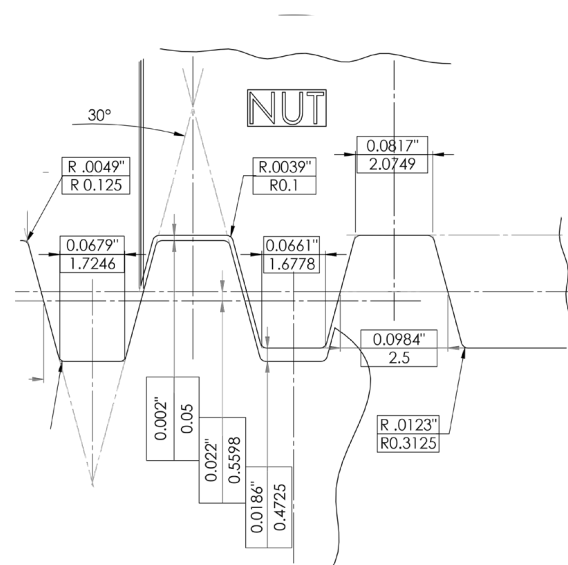

Industry Applications Guide



Casters
(slab, strand, billet, all types)

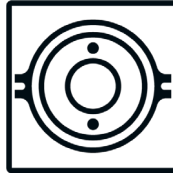

**Hot Strip Drum Shear
Bearing Caps**



**Gear Box &
Pinion Stands**
(all hot mills)



Pickle Lines

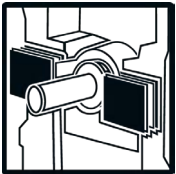

Keeper Plates
(all roughing & finishing mills)



Slitting Lines



**Circular Milling &
Friction Saw Blades
Structural Mills**

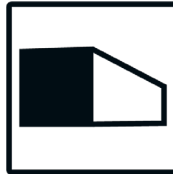

Bar & Billet Mills



Side Trimmers

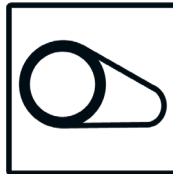

Pipe & Tube Mills

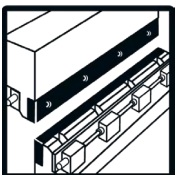

**Cross-Cut Shear
Blades**



**Beam, Rail &
Structural Mills**

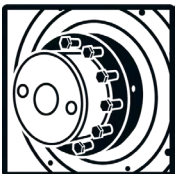

**Plate Mill Leveler
Bearing Caps**

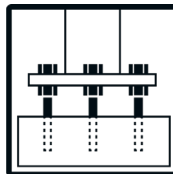

Utilities

APPLICATION GUIDE FOR LOCATION, BENEFITS & TYPES OF AMTEC HYDRAULIC NUTS

Casters (slab, strand, billet, all types)



Type of Nuts

- GX TYPE,
- F-TYPE,
- STEP NUTS,
- Custom designed to suit operating requirements

- Location of Nuts
 - ▶ Vertical mold sections, joining and support applications
 - ▶ Withdrawal-roll segment lock-up into the bow-section
- Benefits of Hydraulic Lock-up
 - ▶ Maintains a positive lock-up and reliable pre-stressing of the leg sections of the withdrawal-roll segment
 - ▶ Minimizes “break-out” due to positive alignment of withdrawal-roll segments
 - ▶ Replaces wedges which cause inherent problems and delays during insertion and removal
 - ▶ Quick, positive and remote pressurizing and depressurizing
 - ▶ Net benefit: increased control of semi-molten cross sections, fewer break-outs, less down time, greater productivity and quality

Gear Box & Pinion Stands (all hot mills)

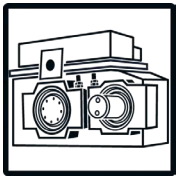

Type of Nuts

- BLOCK NUTS (custom designed)

- Locations of Nuts
 - ▶ Base bolts and/or closure nuts on housing caps, for hot-strip recoiler drives or other mill drive systems
- Benefits of Hydraulic Lock-up
 - ▶ Quick, positive lock-up and release with controlled pre-stress of tie-rods or studs to overcome torque stresses
 - ▶ Net benefit: positive equipment lock-up reduces wear on drive train and optimizes torque transfer

Keeper Plates (all roughing & finishing mills)

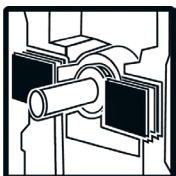

Type of Nuts

- ▶ H-TYPE,
- ▶ STEP NUTS,
- ▶ Special designed

- Location of Nuts
 - ▶ Outboard on end frames of the mill stands for securing keeper plates that hold bearing chocks in place during rolling operations
- Benefits of Hydraulic Lock-up
 - ▶ Quick, positive lock-up and release, with controlled pressure, to overcome axial thrust forces created by the rolling process
 - ▶ Eliminates manual tightening and releasing of mechanical nuts
 - ▶ Eliminates heavy wrenches and tooling to activate nuts
 - ▶ All nuts can be piped to a common, easily accessed header from which all hydraulic nuts can be pressurized or released simultaneously
 - ▶ Net benefit: safety of operating/maintenance staff by elimination of physical strain & injury with faster chock change-out times and greater control of chock positioning

APPLICATION GUIDE FOR LOCATION, BENEFITS & TYPES OF AMTEC HYDRAULIC NUTS

Circular Milling & Friction Saw Blades



Type of Nuts

- F-TYPE
- K-TYPE

- Location of Nuts
 - ▶ Beam, Rail, Structural, Pipe & Tube Mills at the finishing end for cutting sections to custom lengths
- Benefits of Hydraulic Lock-up
 - ▶ Maintains positive lock-up and alignment of circular saw blades
 - ▶ Eliminates the need for jam nuts or repeated re-tightening of mechanical nuts
 - ▶ Rapid clamping and releasing for efficient change-out of circular saw blades
 - ▶ Net Benefit: positive positioning of circular saw blades throughout the operating cycle and ensures minimum wobble of blade and minimum burr on the off-cut

Side Trimmers



Type of Nuts

- F-TYPE
- K-TYPE
- GX-TYPE

- Location of Nuts
 - ▶ Side trimmer heads for retaining circular knives that trim edges of leveled sheet or plate up to 1" thickness or heavier
- Benefits of Hydraulic Lock-up
 - ▶ Quick, positive lock-up and release for knives with controlled pressure
 - ▶ Elimination of heavy wrenches and tooling to tighten and release mechanical nuts
 - ▶ Special package designs to upgrade knife change-out procedures and reduce downtime for knife changes
 - ▶ Net benefit: greater precision, faster knife changes, reduced side trimmed edge rejection rate and greater productivity

Cross-Cut Shears Blades

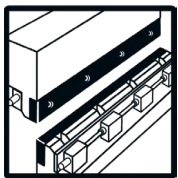

Type of Nuts

- H-TYPE,
- STEP NUTS,
- Custom Designed

- Location of Nuts
 - ▶ Cross-cut shear knives for plate, slabs and coil; in-series H-Type
- Benefits of Hydraulic Lock-up
 - ▶ Quick, positive lock-up and release for shear blades with controlled pressure
 - ▶ Hydraulic power unit or oil handpump rapidly releases pressure, allowing T-Slot blade holder to slide out within seconds
 - ▶ Net benefit: greater precision, faster blade changes, and improved longevity

Plate Mill Leveler Bearing Caps

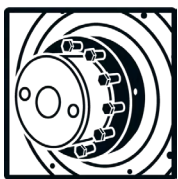

Type of Nuts

- BLOCK NUTS
(custom designed)

- Location of Nuts
 - ▶ Top tie-rod/stud nuts on bearing caps on leveler end frames
- Benefits of Hydraulic Lock-up
 - ▶ Quick, positive lock-up and release with controlled pre-stress of tie-rods to overcome separating forces during plate leveling
 - ▶ Net benefit: faster bearing and roll change-out times without cranes, heavy wrenches and tooling to tighten or loosen mechanical nuts

Hot Strip Drum Shear Bearing Caps



Type of Nuts

- BLOCK NUTS
(custom designed)

- Location of Nuts
 - ▶ Top tie-rod/stud nuts for bearing caps on drum shear end frames
- Benefits of Hydraulic Lock-up
 - ▶ Quick, positive lock-up and release with controlled pre-stress of tie-rods to overcome drum shear separating forces during shearing
 - ▶ Net benefit: faster drum change-out and more consistent crop knife gap settings for reduced crop end scrap. No heavy wrenches or removal tooling required

Pickle Lines



Type of Nuts

- F-TYPE
- K-TYPE

- Location of Nuts
 - ▶ Side trimmer heads for retaining circular knives which trim edges of pickled strip
 - ▶ Welder dies at entry end of pickle tanks
- Benefits of Hydraulic Lock-Up
 - ▶ Quick, positive lock-up and release for knives with controlled pressure
 - ▶ Special package, updated designs to reduce knife change downtime and offer more accurate knife settings
 - ▶ Quick release and removal for knife changes without spacer compensation for knife thickness variations.
 - ▶ Net benefit: greater precision, faster knife changes, reduced slit edge rejection rate from cold mill and increased productivity

Slitting Lines



Type of Nuts

- F-TYPE (F-4 inside frame & F-10 outside frame)
- K-TYPE

- Location of Nuts
 - ▶ Mills, Processing & Service Centers, Tube & Pipe Mills, and custom shape producers for all grades of ferrous and non-ferrous material
- Benefits of Hydraulic Lock-Up
 - ▶ Quick, positive lock-up and release for knives with controlled pressure
 - ▶ Special package, update designs to reduce knife change downtime and offer more accurate knife settings
 - ▶ Net Benefit: controlled pressure input, rapid tooling changes, no need for pressure reset during operating cycle or for weekend downturns, better strip width control, reduction of slit edge rejection rate, resulting in more cost-effective production

Bar & Billet Mills



Type of Nuts

- F-TYPE
- H-TYPE

- Locations of Nuts
 - ▶ Shear knife bolts for crop and cobble knives as well as finish shear knives
- Benefits of Hydraulic Lock-up
 - ▶ Eliminates the need for jam nuts or repeated re-tightening of mechanical nuts due to vibration and temperature variations
 - ▶ Net benefit: improved product straightness, better shape control, greater sheared end quality and more run-time

APPLICATION GUIDE FOR LOCATION, BENEFITS & TYPES OF AMTEC HYDRAULIC NUTS

Tube & Pipe Mills



Type of Nuts

- F-TYPE
- GX-TYPE
- STEP NUTS (custom designed)

- Location of Nuts
 - ▶ Friction and milling saw flanges
 - ▶ Turks head stands & fin-pass stands
 - ▶ All other tooling arbors throughout the mill
 - ▶ Forming roll stands between furnace and cut-off saw on hot pipe production lines
 - ▶ Guide roll stands and scarfing tools on spiral weld production
 - ▶ Cut-off saw flanges for all types of circular saw blades
- Benefits of Hydraulic Lock-up
 - ▶ Maintains positive lock-up and alignment of forming roll sections and saw blades
 - ▶ Eliminates the need for jamb nuts or repeated re-tightening of mechanical nuts
 - ▶ Replaces “superbolts” (multiple axial jack screws) with faster and more reliable lock-up system
 - ▶ Quick release and removal
 - ▶ Net benefit: improved product straightness, fewer diametrical variances and more run-time

Beam, Rail & Structural Mills



Type of Nuts

- GX-TYPE
- BLOCK NUTS
- STEP NUTS (custom designed)

- Location of Nuts
 - ▶ Rolling and straightening arbors/mandrels to retain roll sections
 - ▶ Tie-rod pre-stress nuts to hold sectional mill frames together
 - ▶ Forming roll bearing lock-up in chocks
 - ▶ Circular friction cut-off saw blade flanges
- Benefits of Hydraulic Lock-up
 - ▶ Maintains positive lock-up and alignment for rolling, straightening and cut-off stands
 - ▶ Eliminates the need for jam nuts or repeated re-tightening of mechanical nuts
 - ▶ Replaces “superbolts” (multiple axial jack screws) with a faster and more reliable lock-up system
 - ▶ Quick release and removal
 - ▶ Maintains a tight sectional mill frame by exceeding separational forces
 - ▶ Optimizes roll end-float by controlling bearing location
 - ▶ Net benefit: improved product straightness and section thickness with more runtime

Utilities

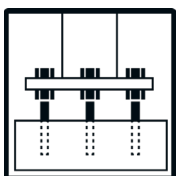

Type of Nuts

- H-TYPE
- Greas-Bloc Nuts

- Location of Nuts
 - ▶ Top side light standard stud bolts, either temporarily pre-tensioning with H-Nuts or permanent installation using Greas-Bloc Nuts
- Benefits of Hydraulic Lock-Up
 - ▶ Quick installation requires no long wrenches or bars, easing strain on technicians
 - ▶ H-nuts pre-tension alternating studs, allowing opposed mechanical nuts to be easily installed. After alternating mechanical nuts are tightened, H-nuts are removed to allow remaining mechanical nuts to be tightened onto the already pre-tensioned light standard
 - ▶ Greas-Bloc Nuts use our handpumps to quickly pressurize the nuts and tension all studs on the light standard. After all nuts are pressurized, the Bloc Ring is tightened against the flange face and then the release of nut pressure provides a permanent, secure mount for the light standard
 - ▶ Net Benefit: faster, safer installation of light standard poles with more accurate tensioning

QUICK REFERENCE GUIDE

Clamp Type	Max Pressure	Max Thread Ø		Max Force	Page	Application
F-8 Standard	700 Bar 10,150 PSI	198mm	7.750in	625 kN 70 tons	16	
F-8 Max Force	700 Bar 10,150 PSI	396mm	15.625in	1671 kN 187 tons	17	
F-8 Aluminum	400 Bar 5,800 PSI	378mm	14.875in	955 kN 107 tons	18	
F-9 Standard	700 Bar 10,150 PSI	198mm	7.750in	625 kN 70 tons	19	
F-9 Max Force	700 Bar 10,150 PSI	396mm	15.625in	1671 kN 187 tons	20	
F-9 Aluminum	400 Bar 5,800 PSI	378mm	14.875in	955 kN 107 tons	21	
K-6 Standard	Based on actuator torque	240mm	9.375in	254 kN 25 tons	30	
K-7 Standard	Based on actuator torque	100mm	3.875in	166 kN 17 tons	31	
K-025.XXX.610	Based on actuator torque	240mm	9.375in	254 kN 25 tons	32	
K-025.XXX.710	Based on actuator torque	100mm	3.875in	166 kN 17 tons	33	
GX-4 Standard	700 Bar 10,150 PSI	452mm	17.750in	2110 kN 237 tons	42	
GX-5 Standard	700 Bar 10,150 PSI	452mm	17.750in	2110 kN 237 tons	43	
H-2 Standard	700 Bar 10,150 PSI	396mm	15.625in	1671 kN 187 tons	50	
H-3 Standard	700 Bar 10,150 PSI	396mm	15.625in	1671 kN 187 tons	51	
H-049	700 Bar 10,150 PSI	T-Slot Mounting		125 kN 14 tons	54	
Step Nuts	700 Bar 10,150 PSI	377mm Bore	14.84in Bore	1405 kN 158 tons	58	
Block Nuts	700 Bar 10,150 PSI	396mm	15.625in	1674 kN 187 tons	60	
Clamp Rings	700 Bar 10,150 PSI	305mm Bore	14.000in Bore	1675 kN 187 tons	64	



F-Nuts

Amtec Hydraclamp™ Hydraulic Clamping Nuts are suitable for steel slitters, side trimmers, choppers and roll-forming lines, which all benefit from the exceptional safety, convenience, efficiency and highly controllable clamping.

Amtec Hydraulic Nuts safely and conveniently replace major mechanical nuts on all types of metal processing lines by eliminating sledge hammers and heavy wrenches, which cause much of the strain and physical injury to the set-up personnel. Bearing damage from hammering nuts is eliminated with Amtec Hydraclamp™ Hydraulic Clamping Nuts. By using Amtec High Pressure Handpumps to pressurize the Amtec Nuts, positive, controlled clamping force is applied with every installation to ensure reliably accurate tooling set-ups. 100% of all effort to pressurize Amtec Hydraulic Nuts is converted to clamping force, eliminating friction on threads which is the prime cause of early thread wear.

All Amtec F-Type Nuts are activated by grease to suit operating specifications. Amtec F-Type Nuts offer self-aligning, annular thrust rings, which create a high force lock to prevent unthreading once pressure is applied.

The extreme internal pressure pushes the thrust ring against the mating tooling and simultaneously forces the nut body to locate against the arbor or shaft threads. Therefore, all threads may be right hand rotation regardless of whether the arbor or shaft rotation is clockwise or counterclockwise. Amtec will custom manufacture all F-Type Nuts to any existing thread form, regardless of thread hand, provided the thread form conforms to international standards.

To compensate for increased weight in larger sized nuts, we offer aircraft grade aluminum nut models at 50-60% the weight of our standard high-strength steel. Comparable durability, performance and quality are guaranteed with all aluminum nuts, although maximum pressure is reduced from 700 bar to 400 bar.

Amtec F-Type Nuts are manufactured from 4140 chromoly steel or QC-10 aircraft aluminum.

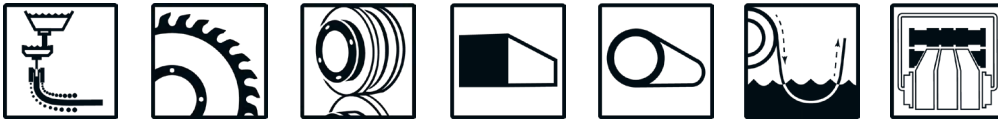

FEATURES:

- Standard black oxide finish for 120°C max. (250°F)
- Special finishes for service up to 240°C max. (460°F)
- 4140 alloy tool steel or QC-10 aircraft aluminum body parts
- Stainless steel, electroless nickel or chromium plating for optional corrosion resistance
- Unidirectional, all steel, high-pressure F-NIPPLE
- All components rated at 840 bar max. (12,180 psi)
- Aluminum nuts are more than half the weight as steel



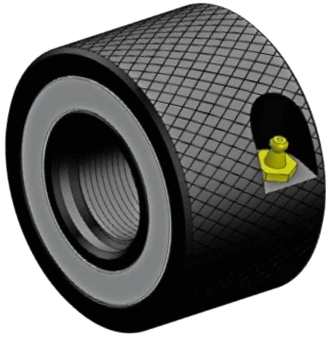

F-Type Nuts

STANDARD SERIES F-8.4 & F-8.10

with RADIALLY LOCATED F-NIPPLE and RELEASE SCREW

Actuated by manual or motorized grease pump. Self-aligning annular thrust ring with 4 or 10 mm maximum axial travel.

Model	Max Arbor Thread Size		Cannot Exceed Minimum Tool Ø		Verify diameters D & E contact an uninterrupted surface				Select Stroke as Required		Nut Width		Ensure Adequate Force Has Been Selected				Weight	
	Max Thread Ø		Nut Diameter		Thrust Ring Size				Thrust Ring Stroke		C		Clamping Force					
	A		B		D - OD		E - ID		S				400 BAR		700 BAR			
	mm	Inch	mm	Inch	mm	Inch	mm	Inch	mm	Inch	mm	Inch	kN	Tons	kN	Tons	KG	Pounds
F-8.405	36	1.750	82	3.228	66	2.598	46	1.811	4	0.157	50	1.969	70	8	123	13	3.0	6.6
F-8.1005	36	1.750	85	3.346	66	2.598	46	1.811	10	0.394	60	2.362	70	8	123	13	3.0	6.6
F-8.407	52	2.000	98	3.858	82	3.228	62	2.441	4	0.157	50	1.969	90	10	158	18	3.0	6.6
F-8.1007	52	2.000	102	4.016	82	3.228	62	2.441	10	0.394	60	2.362	90	10	158	18	3.0	6.6
F-8.408	68	2.625	116	4.567	100	3.937	80	3.150	4	0.157	50	1.969	113	13	198	22	3.0	6.6
F-8.1008	68	2.625	120	4.724	100	3.937	80	3.150	10	0.394	60	2.362	113	13	198	22	3.4	7.5
F-8.409	82	3.250	131	5.157	115	4.528	95	3.740	4	0.157	50	1.969	131	14	230	26	3.4	7.5
F-8.1009	82	3.250	135	5.315	115	4.528	95	3.740	10	0.394	60	2.362	131	14	230	26	4.0	8.8
F-8.410	100	3.875	148	5.827	130	5.118	112	4.409	4	0.157	50	1.969	137	15	239	27	4.5	9.9
F-8.1010	100	3.875	152	5.984	130	5.118	112	4.409	10	0.394	60	2.362	137	15	239	27	5.8	12.8
F-8.411	125	4.875	180	7.087	160	6.299	138	5.433	4	0.157	50	1.969	205	23	360	40	5.1	11.2
F-8.1011	125	4.875	185	7.283	160	6.299	138	5.433	10	0.394	60	2.362	205	23	360	40	6.8	15.0
F-8.412	142	5.625	195	7.677	175	6.890	155	6.102	4	0.157	50	1.969	207	23	363	41	5.5	12.1
F-8.1012	142	5.625	200	7.874	175	6.890	155	6.102	10	0.394	60	2.362	207	23	363	41	7.3	16.1
F-8.4125	156	6.125	210	8.268	190	7.480	170	6.693	4	0.157	50	1.969	226	25	396	45	6.0	13.2
F-8.10125	156	6.125	215	8.465	190	7.480	170	6.693	10	0.394	60	2.362	226	25	396	45	8.5	18.7
F-8.413	165	6.500	220	8.661	200	7.874	180	7.087	4	0.157	50	1.969	238	27	417	47	8.0	17.6
F-8.1013	165	6.500	228	8.976	200	7.874	180	7.087	10	0.394	60	2.362	238	27	417	47	11.0	24.2
F-8.414	186	7.375	242	9.528	222	8.740	202	7.953	4	0.157	50	1.969	266	30	466	52	8.5	18.7
F-8.1014	186	7.375	250	9.843	222	8.740	202	7.953	10	0.394	60	2.362	266	30	466	52	12.0	26.4
F-8.415	198	7.750	262	10.315	240	9.449	215	8.465	4	0.157	50	1.969	357	40	625	70	9.0	19.8
F-8.1015	198	7.750	268	10.551	240	9.449	215	8.465	10	0.394	60	2.362	357	40	625	70	13.5	29.7

Special features or requirements can be accommodated. Kindly contact your local agent or call our office directly.

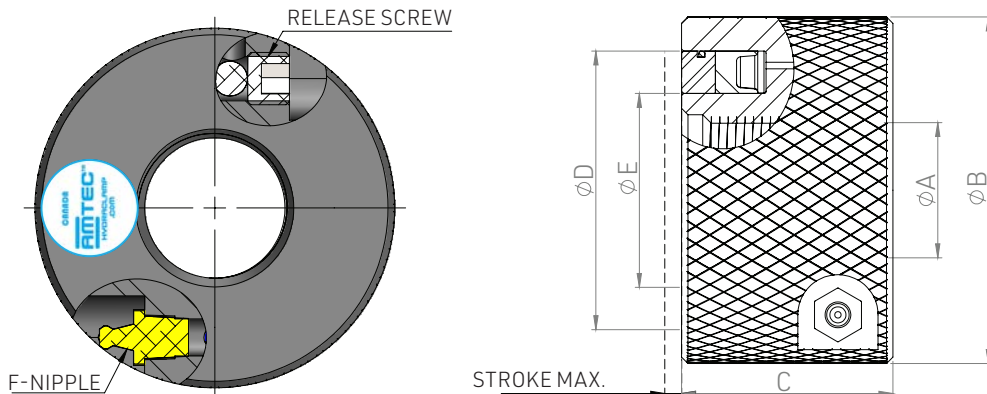



F-Type Nuts

MAX-FORCE SERIES F-8.4 & F-8.10

with RADIALLY LOCATED F-NIPPLE and RELEASE SCREW

Actuated by manual or motorized grease pump. Self-aligning annular thrust ring with 4 or 10 mm maximum axial travel.

Model	Max Arbor Thread Size		Cannot Exceed Minimum Tool Ø		Verify diameters D & E contact an uninterrupted surface				Select Stroke as Required		Ensure Adequate Force Has Been Selected						Weight	
	Max Thread Ø		Nut Diameter		Thrust Ring Size				Thrust Ring Stroke		Nut Width		Clamping Force					
	A		B		D - OD		E - ID		S		C		400 BAR		700 BAR		KG	Pounds
	mm	Inch	mm	Inch	mm	Inch	mm	Inch	mm	Inch	mm	Inch	kN	Tons	kN	Tons		
F-8.415.5	218	8.500	282	11.102	260	10.236	235	9.252	4	0.157	50	1.969	389	43	680	76	13.0	28.6
F-8.415.5	218	8.500	288	11.339	260	10.236	235	9.252	10	0.394	60	2.362	389	43	680	76	14.0	30.8
F-8.416.1	226	8.875	292	11.496	270	10.630	245	9.646	4	0.157	50	1.969	404	45	707	79	10.0	22.0
F-8.1016.1	226	8.875	298	11.732	270	10.630	245	9.646	10	0.394	60	2.362	404	45	707	79	11.5	25.3
F-8.417.0	242	9.500	305	12.008	285	11.220	260	10.236	4	0.157	50	1.969	428	48	749	84	12.0	26.4
F-8.1017.0	242	9.500	313	12.323	285	11.220	260	10.236	10	0.394	60	2.362	428	48	749	84	14.0	30.8
F-8.418.0	260	10.250	338	13.307	310	12.205	280	11.024	4	0.157	55	2.165	556	62	973	109	14.0	30.8
F-8.1018.0	260	10.250	344	13.543	310	12.205	280	11.024	10	0.394	65	2.559	556	62	973	109	16.5	36.3
F-8.419.0	280	11.000	358	14.094	330	12.992	300	11.811	4	0.157	55	2.165	594	67	1039	116	23.5	51.7
F-8.1019.0	280	11.000	364	14.331	330	12.992	300	11.811	10	0.394	65	2.559	594	67	1039	116	25.0	55.0
F-8.419.5	305	12.000	385	15.157	355	13.976	325	12.795	4	0.157	60	2.362	640	71	1121	125	16.0	35.2
F-8.1019.5	305	12.000	392	15.433	355	13.976	325	12.795	10	0.394	70	2.756	640	71	1121	125	24.8	54.6
F-8.420.0	308	12.125	400	15.748	366	14.409	330	12.992	4	0.157	60	2.362	787	88	1377	154	20.0	44.0
F-8.1020.0	308	12.125	406	15.984	366	14.409	330	12.992	10	0.394	70	2.756	787	88	1377	154	35.0	77.0
F-8.1021.0	336	13.250	448	17.638	400	15.748	360	14.173	10	0.157	70	2.756	955	107	1671	187	39.0	85.8
F-8.1022.0	366	13.250	460	18.110	422	16.614	390	15.354	10	0.394	70	2.756	816	91	1428	160	37.0	81.4
F-8.1023.0	396	15.625	486	19.134	450	17.717	420	16.535	10	0.157	70	2.756	820	92	1435	161	32.5	71.5

Special features or requirements can be accommodated. Kindly contact your local agent or call our office directly.

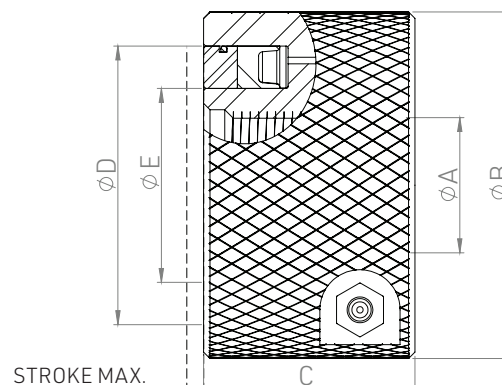
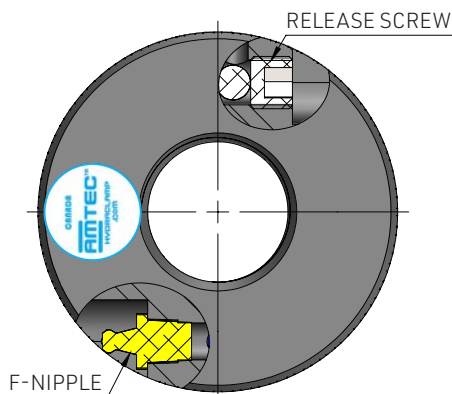

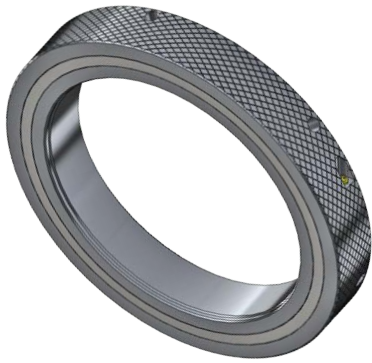

F-Type Nuts

AIRCRAFT QUALITY ALUMINUM SERIES F-8.4 & F-8.10

with RADIALLY LOCATED F-NIPPLE & RELEASE SCREW

Actuated by manual or motorized grease pump. Self-aligning annular thrust ring with 4 or 10 mm maximum axial travel.

Model	Max Arbor Thread Size		Cannot Exceed Minimum Tool Ø		Verify diameters D & E contact an uninterrupted surface				Select Stroke as Required		Nut Width		Ensure Adequate Force Has Been Selected		Weight	
	Max Thread Ø		Nut Diameter		Thrust Ring Size				Thrust Ring Stroke		Clamping Force		400 BAR			
	A	B	D - OD	E - ID	S	C										
	mm	Inch	mm	Inch	mm	Inch	mm	Inch	mm	Inch	mm	Inch	kN	Tons	KG	Pounds
F-8.411.017	108	4.250	183	7.205	160	6.299	138	5.433	4	0.157	55	1.969	205	23	2.0	4.4
F-8.1011.017	108	4.250	188	7.402	160	6.299	138	5.433	10	0.394	65	2.362	205	23	3.0	6.6
F-8.412.017	122	4.812	200	7.874	175	6.890	155	6.102	4	0.157	55	1.969	207	23	3.5	7.7
F-8.1012.017	122	4.812	205	8.071	175	6.890	155	6.102	10	0.394	65	2.362	207	23	4.5	9.9
F-8.413.017	145	5.750	225	8.858	200	7.874	180	7.087	4	0.157	55	1.969	238	27	5.0	11.0
F-8.1013.017	145	5.750	233	9.173	200	7.874	180	7.087	10	0.394	65	2.362	238	27	6.0	13.2
F-8.414.017	166	6.500	246	9.685	222	8.740	202	7.953	4	0.157	55	1.969	266	30	4.0	8.8
F-8.1014.017	166	6.500	254	10.000	222	8.740	202	7.953	10	0.394	65	2.362	266	30	5.0	11.0
F-8.415.517	196	7.750	288	11.339	260	10.236	235	9.252	4	0.157	55	1.969	389	43	10.0	22.0
F-8.1015.517	196	7.750	294	11.575	260	10.236	235	9.252	10	0.394	65	2.362	389	43	10.0	22.0
F-8.416.1117	206	8.125	298	11.732	270	10.630	245	9.646	4	0.157	55	1.969	404	45	6.0	13.2
F-8.1016.117	206	8.125	304	11.969	270	10.630	245	9.646	10	0.394	65	2.362	404	45	7.0	15.4
F-8.417.017	222	8.750	313	12.323	285	11.220	260	10.236	4	0.157	55	1.969	428	48	7.0	15.4
F-8.1017.017	222	8.750	319	12.559	285	11.220	260	10.236	10	0.394	65	2.362	428	48	8.0	17.6
F-8.418.017	242	9.500	344	13.543	310	12.205	280	11.024	4	0.157	60	2.362	556	62	8.0	17.6
F-8.1018.017	242	9.500	350	13.780	310	12.205	280	11.024	10	0.394	70	2.756	556	62	10.0	22.0
F-8.419.017	260	10.250	364	14.331	330	12.992	300	11.811	4	0.157	60	2.362	594	67	10.0	22.0
F-8.1019.017	260	10.250	370	14.567	330	12.992	300	11.811	10	0.394	70	2.756	594	67	13.0	28.6
F-8.419.517	286	11.250	392	15.433	355	13.976	325	12.795	4	0.157	65	2.559	640	71	10.0	22.0
F-8.1019.517	286	11.250	398	15.669	355	13.976	325	12.795	10	0.394	75	2.953	640	71	11.0	24.2
F-8.420.017	288	11.375	408	16.063	366	14.409	330	12.992	4	0.157	65	2.559	787	88	14.0	30.8
F-8.1020.017	288	11.375	414	16.299	366	14.409	330	12.992	10	0.394	75	2.953	787	88	15.0	33.0
F-8.1021.017	314	12.375	460	18.110	400	15.748	360	14.173	10	0.394	75	2.953	955	107	18.0	39.6
F-8.1022.017	348	13.750	470	18.504	422	16.614	390	15.354	10	0.394	75	2.953	816	91	18.0	39.6
F-8.1022.517	368	14.500	490	19.291	442	17.402	410	16.142	10	0.394	75	2.953	856	96	18.5	40.7
F-8.1023.017	378	14.875	496	19.528	450	17.717	420	16.535	10	0.394	75	2.953	820	92	19.0	41.8

Special features or requirements can be accommodated. Kindly contact your local agent or call our office directly.

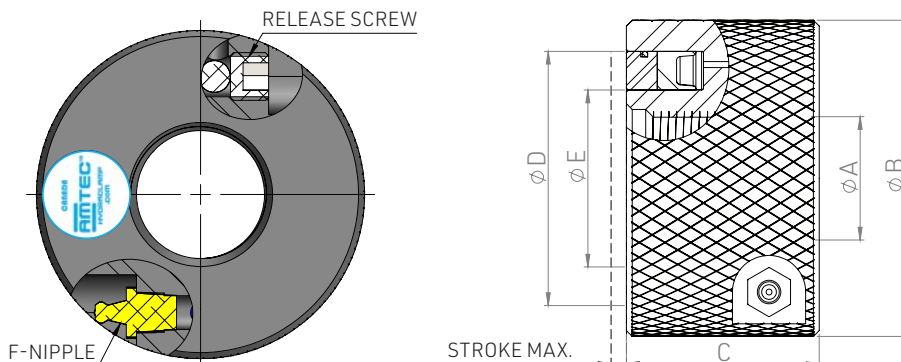



F-Type Nuts

STANDARD SERIES F-9.4 & F-9.10

with AXIAL F-NIPPLE & RELEASE SCREW

Actuated by manual or motorized grease pump. Self-aligning annular thrust ring with 4 or 10 mm maximum axial travel.

Model	Max Arbor Thread Size		Cannot Exceed Minimum Tool Ø		Verify diameters D & E contact an uninterrupted surface				Select Stroke as Required		Ensure Adequate Force Has Been Selected				Weight			
	Max Thread Ø		Nut Diameter		Thrust Ring Size				Thrust Ring Stroke		Nut Width		Clamping Force					
	A		B		D - OD		E - ID		S		C		400 BAR		700 BAR			
	mm	Inch	mm	Inch	mm	Inch	mm	Inch	mm	Inch	mm	Inch	kN	Tons	kN	Tons	KG	Pounds
F-9.405	36	1.750	82	3.228	66	2.598	46	1.811	4	0.157	50	1.969	70	8	123	13	3.0	6.6
F-9.1005	36	1.750	85	3.346	66	2.598	46	1.811	10	0.394	60	2.362	70	8	123	13	3.0	6.6
F-9.407	52	2.000	98	3.858	82	3.228	62	2.441	4	0.157	50	1.969	90	10	158	18	3.0	6.6
F-9.1007	52	2.000	102	4.016	82	3.228	62	2.441	10	0.394	60	2.362	90	10	158	18	3.0	6.6
F-9.408	68	2.625	116	4.567	100	3.937	80	3.150	4	0.157	50	1.969	113	13	198	22	3.0	6.6
F-9.1008	68	2.625	120	4.724	100	3.937	80	3.150	10	0.394	60	2.362	113	13	198	22	3.4	7.5
F-9.409	82	3.250	131	5.157	115	4.528	95	3.740	4	0.157	50	1.969	131	14	230	26	3.4	7.5
F-9.1009	82	3.250	135	5.315	115	4.528	95	3.740	10	0.394	60	2.362	131	14	230	26	4.0	8.8
F-9.410	100	3.875	148	5.827	130	5.118	112	4.409	4	0.157	50	1.969	137	15	239	27	4.5	9.9
F-9.1010	100	3.875	152	5.984	130	5.118	112	4.409	10	0.394	60	2.362	137	15	239	27	5.8	12.8
F-9.411	125	4.875	180	7.087	160	6.299	138	5.433	4	0.157	50	1.969	205	23	360	40	5.1	11.2
F-9.1011	125	4.875	185	7.283	160	6.299	138	5.433	10	0.394	60	2.362	205	23	360	40	6.8	15.0
F-9.412	142	5.625	195	7.677	175	6.890	155	6.102	4	0.157	50	1.969	207	23	363	41	5.5	12.1
F-9.1012	142	5.625	200	7.874	175	6.890	155	6.102	10	0.394	60	2.362	207	23	363	41	7.3	16.1
F-9.4125	156	6.125	210	8.268	190	7.480	170	6.693	4	0.157	50	1.969	226	25	396	45	6.0	13.2
F-9.10125	156	6.125	215	8.465	190	7.480	170	6.693	10	0.394	60	2.362	226	25	396	45	8.5	18.7
F-9.413	165	6.500	220	8.661	200	7.874	180	7.087	4	0.157	50	1.969	238	27	417	47	8.0	17.6
F-9.1013	165	6.500	228	8.976	200	7.874	180	7.087	10	0.394	60	2.362	238	27	417	47	11.0	24.2
F-9.414	186	7.375	242	9.528	222	8.740	202	7.953	4	0.157	50	1.969	266	30	466	52	8.5	18.7
F-9.1014	186	7.375	250	9.843	222	8.740	202	7.953	10	0.394	60	2.362	266	30	466	52	12.0	26.4
F-9.415	198	7.750	262	10.315	240	9.449	215	8.465	4	0.157	50	1.969	357	40	625	70	9.0	19.8
F-9.1015	198	7.750	268	10.551	240	9.449	215	8.465	10	0.394	60	2.362	357	40	625	70	13.5	29.7

Special features or requirements can be accommodated. Kindly contact your local agent or call our office directly.

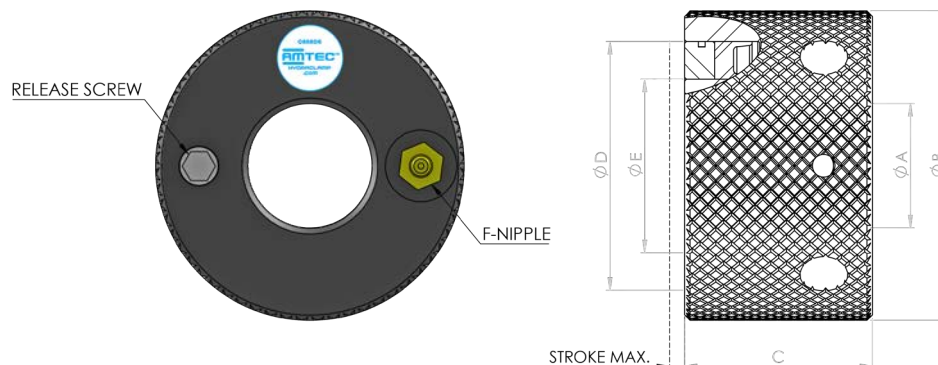

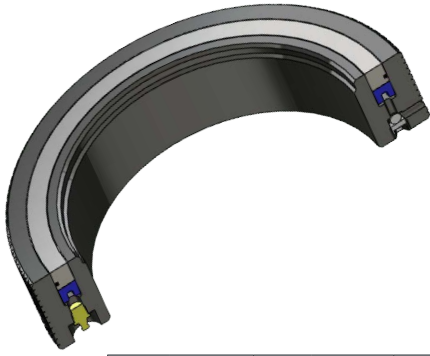

F-Type Nuts

MAX-FORCE SERIES F-9.4 & F-9.10

with AXIAL F-NIPPLE & RELEASE SCREW

Actuated by manual or motorized grease pump. Self-aligning annular thrust ring with 4 or 10 mm maximum axial travel.

Model	Max Arbor Thread Size		Cannot Exceed Minimum Tool Ø		Verify diameters D & E contact an uninterrupted surface				Select Stroke as Required		Nut Width		Ensure Adequate Force Has Been Selected				Weight	
	Max Thread Ø		Nut Diameter		Thrust Ring Size				Thrust Ring Stroke		Clamping Force							
	A		B		D - OD		E - ID		S		C		400 BAR		700 BAR			
	mm	Inch	mm	Inch	mm	Inch	mm	Inch	mm	Inch	mm	Inch	kN	Tons	kN	Tons	KG	Pounds
F-9.415.5	218	8.500	282	11.102	260	10.236	235	9.252	4	0.157	50	1.969	389	43	680	76	13.0	28.6
F-9.1015.5	218	8.500	288	11.339	260	10.236	235	9.252	10	0.394	60	2.362	389	43	680	76	14.0	30.8
F-9.416.1	226	8.875	292	11.496	270	10.630	245	9.646	4	0.157	50	1.969	404	45	707	79	10.0	22.0
F-9.1016.1	226	8.875	298	11.732	270	10.630	245	9.646	10	0.394	60	2.362	404	45	707	79	11.5	25.3
F-9.417.0	242	9.500	305	12.008	285	11.220	260	10.236	4	0.157	50	1.969	428	48	749	84	12.0	26.4
F-9.1017.0	242	9.500	313	12.323	285	11.220	260	10.236	10	0.394	60	2.362	428	48	749	84	14.0	30.8
F-9.418.0	260	10.250	338	13.307	310	12.205	280	11.024	4	0.157	55	2.165	556	62	973	109	14.0	30.8
F-9.1018.0	260	10.250	344	13.543	310	12.205	280	11.024	10	0.394	65	2.559	556	62	973	109	16.5	36.3
F-9.419.0	280	11.000	358	14.094	330	12.992	300	11.811	4	0.157	55	2.165	594	67	1039	116	23.5	51.7
F-9.1019.0	280	11.000	364	14.331	330	12.992	300	11.811	10	0.394	65	2.559	594	67	1039	116	25.0	55.0
F-9.419.5	305	12.000	385	15.157	355	13.976	325	12.795	4	0.157	60	2.362	640	71	1121	125	16.0	35.2
F-9.1019.5	305	12.000	392	15.433	355	13.976	325	12.795	10	0.394	70	2.756	640	71	1121	125	24.8	54.6
F-9.420.0	308	12.125	400	15.748	366	14.409	330	12.992	4	0.157	60	2.362	787	88	1377	154	20.0	44.0
F-9.1020.0	308	12.125	406	15.984	366	14.409	330	12.992	10	0.394	70	2.756	787	88	1377	154	35.0	77.0
F-9.1021.0	336	13.250	448	17.638	400	15.748	360	14.173	10	0.157	70	2.756	955	107	1671	187	39.0	85.8
F-9.1022.0	366	13.250	460	18.110	422	16.614	390	15.354	10	0.394	70	2.756	816	91	1428	160	37.0	81.4
F-9.1023.0	396	15.625	486	19.134	450	17.717	420	16.535	10	0.157	70	2.756	820	92	1435	161	32.5	71.5

Special features or requirements can be accommodated. Kindly contact your local agent or call our office directly.

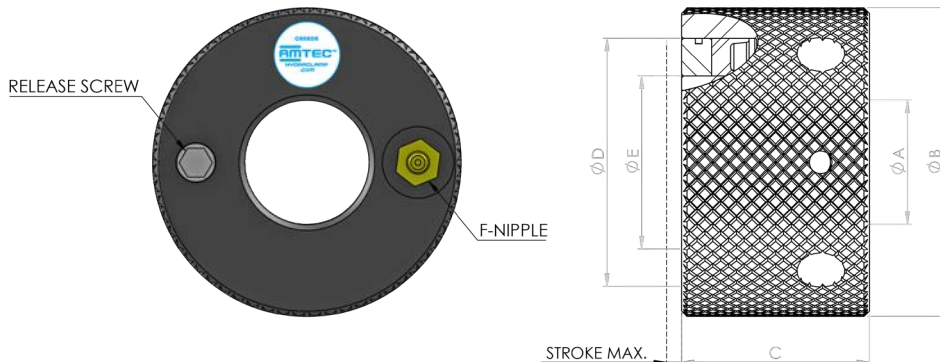



F-Type Nuts

AIRCRAFT QUALITY ALUMINUM SERIES F-9.4 & F-9.10

with AXIAL F-NIPPLE & RELEASE SCREW

Actuated by manual or motorized grease pump. Self-aligning annular thrust ring with 4 or 10 mm maximum axial travel.

Model	Max Arbor Thread Size		Cannot Exceed Minimum Tool Ø		Verify diameters D & E contact an uninterrupted surface				Select Stroke as Required		Ensure Adequate Force Has Been Selected		Weight			
	Max Thread Ø		Nut Diameter		Thrust Ring Size		Thrust Ring Stroke		Nut Width		Clamping Force					
	mm	Inch	mm	Inch	D - OD	E - ID	mm	Inch	mm	Inch	mm	Inch	kN	Tons		
F-9.411.017	108	4.250	183	7.205	160	6.299	138	5.433	4	0.157	55	1.969	205	23	2.0	4.4
F-9.1011.017	108	4.250	188	7.402	160	6.299	138	5.433	10	0.394	65	2.362	205	23	3.0	6.6
F-9.412.017	122	4.812	200	7.874	175	6.890	155	6.102	4	0.157	55	1.969	207	23	3.5	7.7
F-9.1012.017	122	4.812	205	8.071	175	6.890	155	6.102	10	0.394	65	2.362	207	23	4.5	9.9
F-9.413.017	145	5.750	225	8.858	200	7.874	180	7.086	4	0.157	55	1.969	238	27	5.0	11.0
F-9.1013.017	145	5.750	233	9.173	200	7.874	180	7.086	10	0.394	65	2.362	238	27	6.0	13.2
F-9.414.017	166	6.500	246	9.685	222	8.740	202	7.952	4	0.157	55	1.969	266	30	4.0	8.8
F-9.1014.017	166	6.500	254	10.000	222	8.740	202	7.952	10	0.394	65	2.362	266	30	5.0	11.0
F-9.415.517	196	7.750	288	11.339	260	10.236	235	9.252	4	0.157	55	1.969	389	43	10.0	22.0
F-9.1015.517	196	7.750	294	11.575	260	10.236	235	9.252	10	0.394	65	2.362	389	43	10.0	22.0
F-9.416.1117	206	8.125	298	11.732	270	10.630	245	9.646	4	0.157	55	1.969	404	45	6.0	13.2
F-9.1016.117	206	8.125	304	11.969	270	10.630	245	9.646	10	0.394	65	2.362	404	45	7.0	15.4
F-9.417.017	222	8.750	313	12.323	285	11.220	260	10.236	4	0.157	55	1.969	428	48	7.0	15.4
F-9.1017.017	222	8.750	319	12.559	285	11.220	260	10.236	10	0.394	65	2.362	428	48	8.0	17.6
F-9.418.017	242	9.500	344	13.543	310	12.205	280	11.024	4	0.157	60	2.362	556	62	8.0	17.6
F-9.1018.017	242	9.500	350	13.780	310	12.205	280	11.024	10	0.394	70	2.756	556	62	10.0	22.0
F-9.419.017	260	10.250	364	14.331	330	12.992	300	11.811	4	0.157	60	2.362	594	67	10.0	22.0
F-9.1019.017	260	10.250	370	14.567	330	12.992	300	11.811	10	0.394	70	2.756	594	67	13.0	28.6
F-9.419.517	286	11.250	392	15.433	355	13.976	325	12.795	4	0.157	65	2.559	640	71	10.0	22.0
F-9.1019.517	286	11.250	398	15.669	355	13.976	325	12.795	10	0.394	75	2.953	640	71	11.0	24.2
F-9.420.017	288	11.375	408	16.063	366	14.409	330	12.992	4	0.157	65	2.559	787	88	14.0	30.8
F-9.1020.017	288	11.375	414	16.299	366	14.409	330	12.992	10	0.394	75	2.953	787	88	15.0	33.0
F-9.1021.017	314	12.375	460	18.110	400	15.748	360	14.173	10	0.394	75	2.953	955	107	18.0	39.6
F-9.1022.017	348	13.750	470	18.504	422	16.614	390	15.354	10	0.394	75	2.953	816	91	18.0	39.6
F-9.1022.517	368	14.500	490	19.291	442	17.402	410	16.142	10	0.394	75	2.953	856	96	18.5	40.7
F-9.1023.017	378	14.875	496	19.528	450	17.717	420	16.535	10	0.394	75	2.953	820	92	19.0	41.8

Special features or requirements can be accommodated. Kindly contact your local agent or call our office directly.

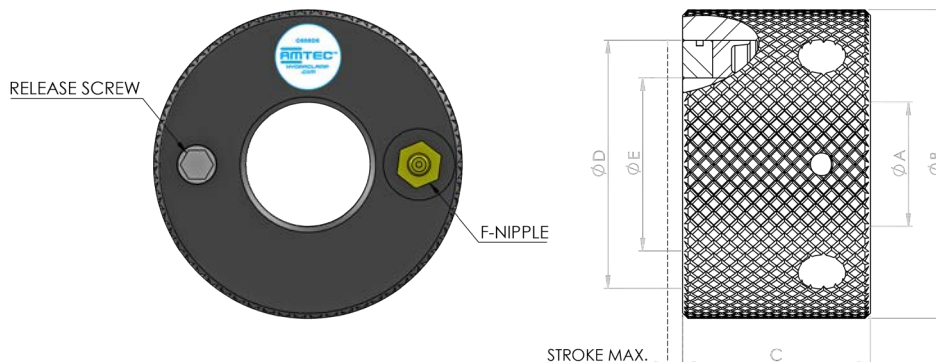



F-Type Nuts

Spare Parts Replacement Instructions

F-Type Nuts are pressurized through a high-pressure F-Nipple located on the end face (axial surface) or on the OD (radial surface) of the nut by either a hand or motorized pump.

1. Amtec repair kits contain all components for a complete F-Type Nut rebuild; each model has a specific kit number.
2. F-Nipples or release screws only need replacement due to wear or damage, or when leakage occurs after being securely tightened by hand using an 11mm or 7/16" socket and wrench for the F-Nipple, or 6mm wrench for the release screw.
3. F-Nipples must be installed with two wraps of Teflon tape around the 1/8" NPT threads, or installed with thread sealant, before tightening with socket and wrench as described above.
4. Release screws consist of a flat point hex socket set screw and a steel ball. The assembly consists of an M12 set screw and 8mm ball for Standard Series Nuts, or an M14 set screw and 10mm ball for Max Force Series Nuts.
5. Either release screw assembly is to be hand tight only using a 6mm hex wrench.
6. The part numbers for Amtec F-Nipples and Release Screw Assemblies are as follows:
 - F-Nipples - 710.101.005
 - Release Screw Assembly Standard - 719.001.012.001
 - Release Screw Assembly Max Force - 719.001.014.001
 (note: 719.001.014.001 is also used for all Aluminum Series F-Nuts)
7. The main seal, located under the steel thrust ring, is Amtec's proprietary dual durometer U-Cup seal, which needs replacement only when grease leakage is observed around the thrust ring.
8. The steel thrust ring needs replacement when it is no longer flat and concentric, or severely deformed on the edges. The O-Ring in the OD of the thrust is not part of the sealing system, but holds the thrust ring in the pressure chamber during handling.
9. To remove the thrust ring: Place the nut on the arbor in a press, where uniform pressure may be applied over the entire thrust ring surface, and maintain parallelism with the nut body by contact tooling or a press platten.
10. Gradually increase grease pressure through the F-Nipple using an Amtec Hydraclamp Handpump, with the release screw tight.
11. Slowly back off (loosen) the nut on the threaded arbor, or gradually open the pressure, to allow the thrust ring to be evenly pushed out from the pressure chamber.
12. Partial support of the thrust ring (such as in a bench vice) will result in distortion of the thrust ring.
13. To remove the seal, continue the operation as described above until the seal is well proud of the nut end face.
14. Stop pumping pressure and remove the nut from the arbor or press.
15. The thrust ring is free and can be examined for damage, and the seal can be pulled free from the nut body.
16. The pressure chamber must be thoroughly cleaned of all grease and contamination, and then inspected for any surface damage. Any damage must be repaired before replacing new seal or thrust ring.
17. To install the seal, place the Amtec seal onto the face of the nut, over the pressure chamber wall, with the "lips" toward the nut.
18. Insert a short section of the inner seal lip into the pressure chamber groove, and then manually pinch the seal lips together to allow a short section of the out seal lip to enter the groove. Clean bare hands are the best tools.
19. While keeping pressure on the heel of the seal (blue section) with one hand, progressively push the inner seal lip into the groove while pinching the outer seal lip so that the seal lips enter the groove without folding over or puckering.
20. Progressively push the seal lower into the groove as installation proceeds.
21. Once 75-80 mm of seal perimeter has been partially inserted into the groove, a blunt hardwood "assist bar" can be employed, if the fingers are complaining. (We use a 20 mm diameter hard maple rod with one end shaped to a blunt wedge and sanded smooth).

22. Continue inserting the inner seal lip into the groove while applying radial pressure on the outer seal lip with the "assist bar," sufficient to enter the outer seal lip into the groove.
23. Remember to progressively push the seal further into the groove as you insert the seal lips.
24. Do not allow any wood or foreign particles to get pushed into the groove with the seal. Do not use metal tools.
25. For a larger diameter seal, work alternately at two or three spots around the seal from the first insertion location to ensure the seal does not get stretched and become too long to fit naturally into the groove.
26. Once the seal is fully into the groove, gradually push the seal to the bottom of the groove using the wooden "assist bar."
27. To install the thrust ring, first inspect the thrust ring to ensure it is flat and free of mechanical damage and thoroughly cleaned, with the retainer O-Ring installed in the OD groove.
28. Insert the thrust ring with the sharp edges into the groove and push down uniformly against the seal until it is flush with the face of the nut.
29. Install the Amtec Nut onto the arbor thread and snug against a full arbor of tooling or in a press.
30. Open the release screw in the Amtec Nut (6 mm hex) one full turn.
31. Apply the Amtec handpump onto the F-Nipple in the Amtec Nut and pump grease into the nut until all air bubbles stop and grease flows smoothly out of the release screw orifice.
32. Close the release screw hand tight.
33. The Amtec Nut is now ready for pressurizing in accordance with F-Type and handpump operating instructions.

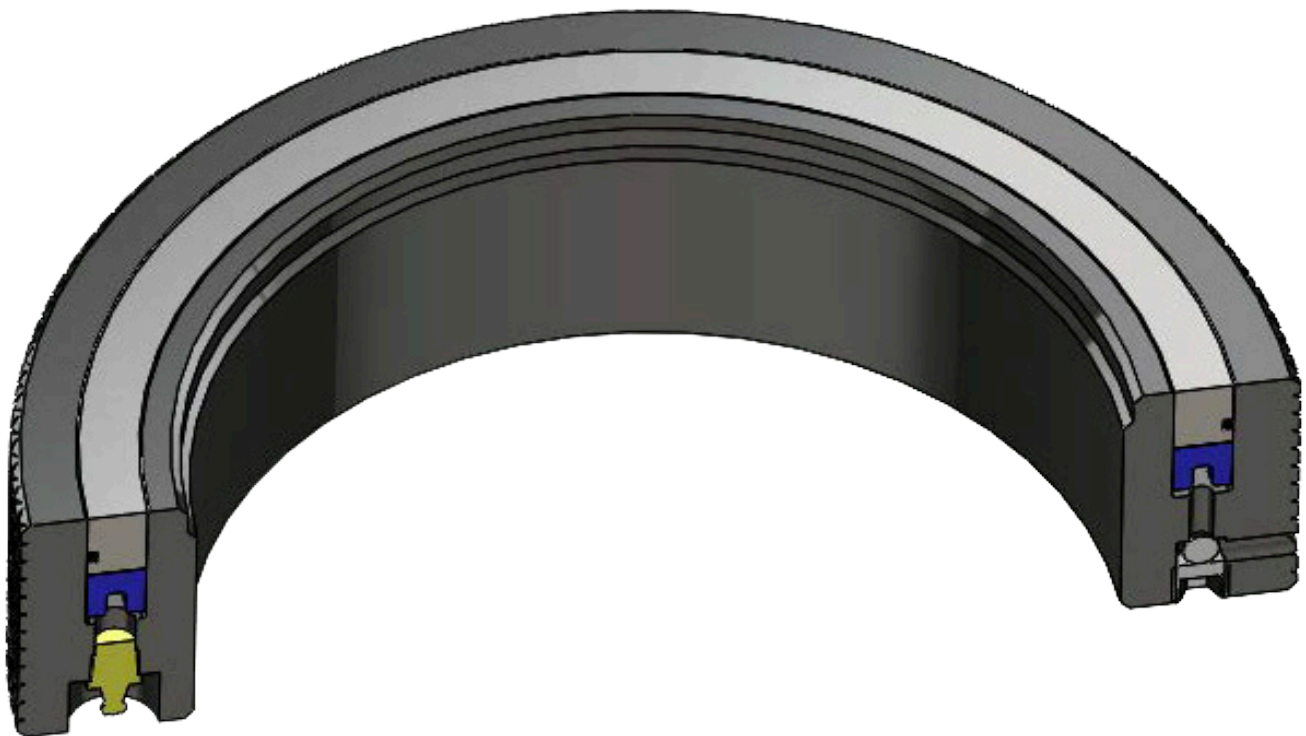



F-Type Nuts

Operating Instructions

F-Type Nuts are pressurized through a high-pressure F-Nipple located on the end face (axial surface) or on the OD (radial surface) of the nut by either a hand or motorized pump.

A. To Install Nuts and Apply Pressure

- Clean the threads and contact faces of the F-Type Nuts, arbors and mating tooling, and also ensure all tooling is packed solidly together on the arbor.
- Assemble the F-Type Nuts on the arbors and snug them by hand against mating tooling, then back off 10 to 20 degrees to ensure only the thrust ring will clamp the tooling and provide easy release later.
- The thrust ring must be flush with the face of the Amtec Nut; if not see Section B.
- Close the release screw using the provided 6 mm hex wrench (hand tight only - no power tools).
- Wipe the face of the Amtec F-Nipple with a clean thumb to ensure contamination is not pumped into the nut.
- Apply Amtec handpump's F-Coupler firmly over the F-Nipple, close the black thumb screw (pressure release valve) on the Handpump and then pump the handle until the desired pressure is obtained on the pressure gauge. (See operating instructions for Amtec handpumps on page 66.)
- Open the black thumb screw on the handpump 1/4 turn; the reading on the pressure gauge will be reduced to zero instantly. Then with a slight rotating motion of the handpump, remove the F-Coupler from the F-Nipple.
- Observe the F-Nipple for a few seconds to ensure no leakage occurs (tighten or replace F-Nipple as required).
- The Amtec F-Type Nut is now fully pressurized with the thrust ring giving uniform axial pressure to the mating tooling.

B. To Release Pressure and Remove Nuts

- Open the release screw 1/4 turn with the provided 6 mm hex wrench.
- NOTE: Cover the bleed hole with a rag or paper towel to ensure all expelled grease is contained, then discard immediately to prevent contamination of equipment.
- Insert an Amtec Hand Assist Bar (see page 76) in the peripheral holes of the nut to first tighten the F-Type Nut against the adjacent tooling to compress the thrust ring flush with the face of the nut and ready for subsequent use. This procedure will also protect the thrust ring from damage.
- Remove the Amtec Nuts from the arbors and place on a wooden-topped bench to prevent damage to the nut faces.
- Tooling may now be removed.

C. Remarks

- DO NOT apply pressure to the F-Type Nuts when nuts are "off-line." The thrust ring has no retainer and can be forced out of the pressure chamber, causing distortion of the thrust ring and possible rupture of the seal.
- Use only genuine Amtec F-Nipples, Release Screws, Seals, Thrust Rings and Handpumps to guarantee clamping reliability.
- Use only Amtec approved grease (see page 77). DO NOT use hand filled grease tube systems. Air bubbles may be introduced into the nut, risking variable clamping forces, and also creating hazards when releasing pressure.
- Always change cartridges on a clean bench with clean hands. Dirt in the valves will cause malfunction of the handpump.
- For videos on F-nut installation and removal, please visit our website.

D. Service

- For service and spare parts contact your local agent or call our office directly.

Amtec Hydraclamp Thread Builder Code

Amtec Hydraclamp offers all standard machine threads on the market. See page 7 for more details on threads. Amtec Hydraclamp requires the thread form, diameter, pitch and rotation direction at time of order. Below is the Amtec Hydraclamp how to order code for thread information.

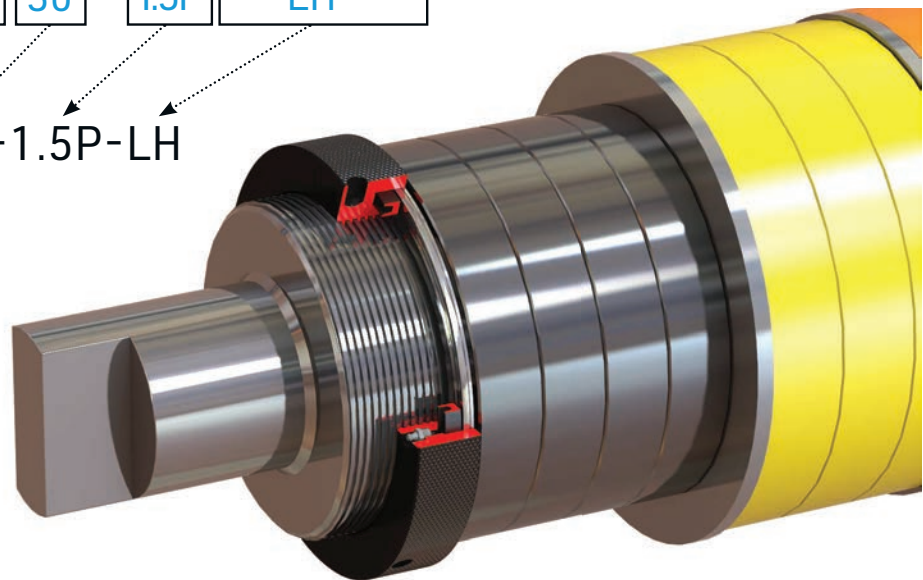
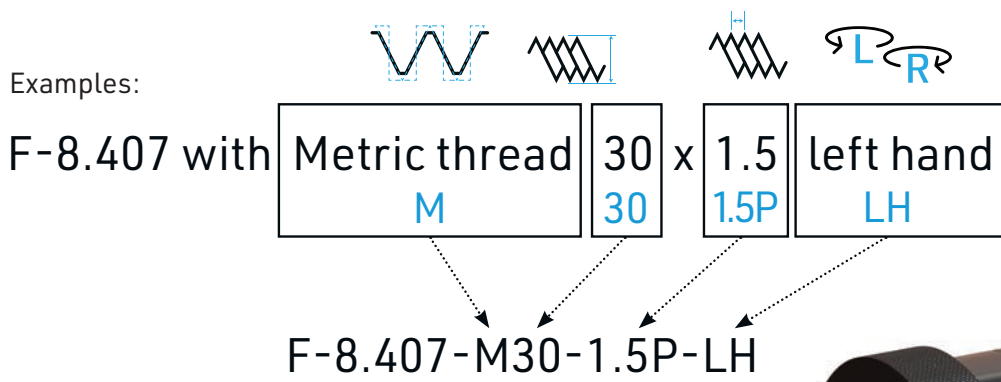
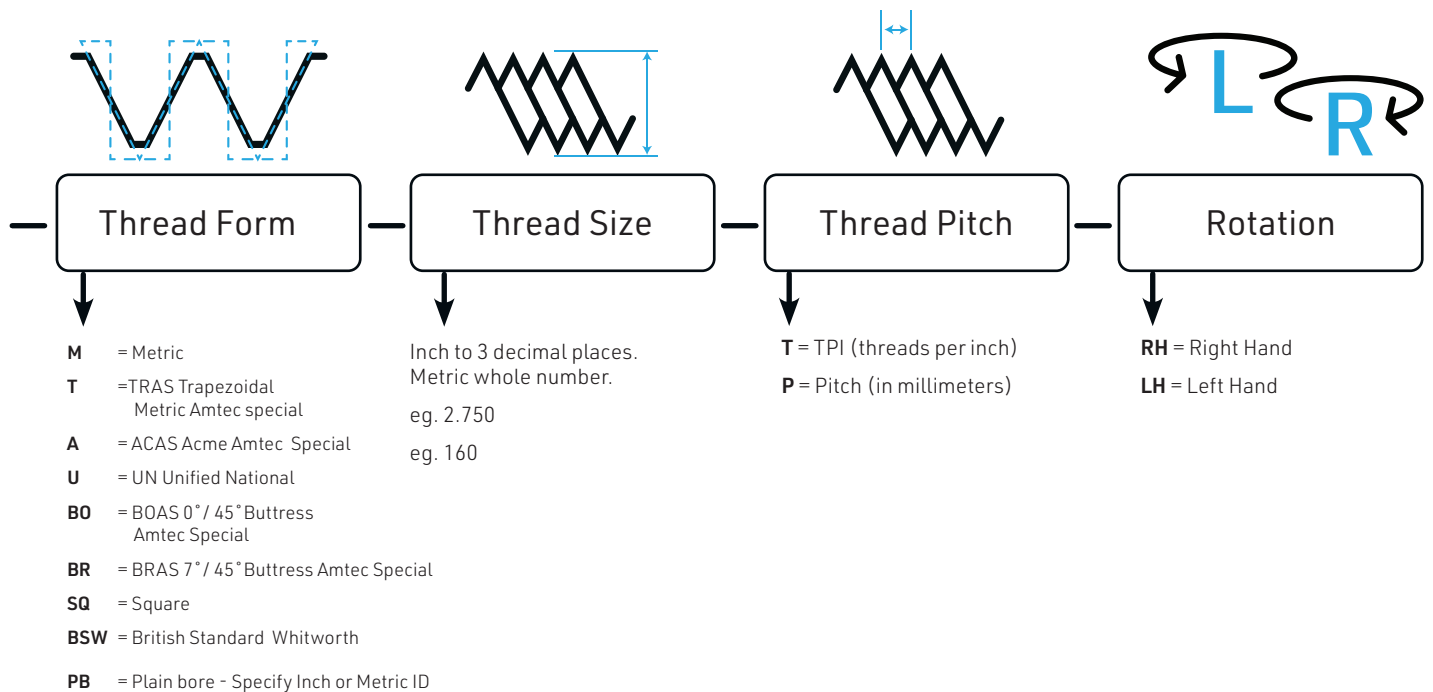

F-Type Nuts Accessories

F-Type Nuts are pressurized through a high-pressure F-Nipple located on the end face or on the OD of the nut, by either a hand or motorized pump.

F-Nipple

Part Number: 710.101.005

Specially engineered high-pressure check valve.

See page 74 for details.



F-Coupler

Part Number: 641.101.103

Heavy duty Four-Jaw coupler.

See page 75 for details.



Assist Bars

Part Number: 801.101.***.***

Install and remove nuts with ease.

See page 76 for details.



High-Pressure Handpumps

Part Number: 112.100.200-*** and 112.110.210-***

The best handpump in the industry; rated for over 1000 bar.

See page 66 for details.

Grease Tube Cartridges

Part Number: 801.200.002

Also available in buckets and drums.

See page 77 for details.



Replacement Parts

Replacement parts are available for all F-Nuts.

Contact Amtec or your local distributor for more information.





K-Nuts

Amtec Hydraclamp™ Hydraulic Clamping Nuts are suitable for steel slitters, side trimmers, choppers and roll-forming lines, which all benefit from the exceptional safety, convenience, efficiency and highly controllable clamping.

Amtec Hydraulic Nuts safely and conveniently replace major mechanical nuts on all types of metal processing lines by eliminating sledge hammers and heavy wrenches, which cause much of the strain and physical injury to the set-up personnel. Bearing damage from hammering nuts is eliminated with Amtec Hydraclamp™ Hydraulic Clamping Nuts. Our piston activated hydraulic nuts provide positive, controlled clamping force applied with every installation to ensure reliably accurate tooling set-ups. Using hydraulic energy to create clamping force eliminates friction on threads, which is the prime cause of early thread wear. All Amtec K-Type Nuts are actuated by pistons pressurizing a grease medium. Amtec K-Type Nuts offer self-aligning, annular thrust rings that create a high force to prevent unthreading once pressure is applied. The extreme internal pressure pushes thrust rings against the mating tooling and simultaneously forces the nut body to locate against the arbor or shaft threads. Therefore, all threads may be right hand rotation regardless of clockwise or counterclockwise shaft or arbor rotation. Amtec will custom manufacture all K-Type Nuts to any existing thread form, regardless of thread hand, provided the thread form conforms to international standards.

Amtec K-Type Nuts are manufactured from 4140 chromoly steel to withstand up to 700 bar (10,150 PSI) without stress or fatigue. All Amtec K-nuts are available with indicator pins that pop up when clamping pressure is met.





FEATURES:

- Standard black oxide finish for 120°C max. (250°F)
- Alloy tool steel body parts
- Stainless steel, electroless nickel or chromium
- Plating for optional corrosion resistance
- Self-aligning annular thrust ring
- Clean, efficient, hand-operated clamping system

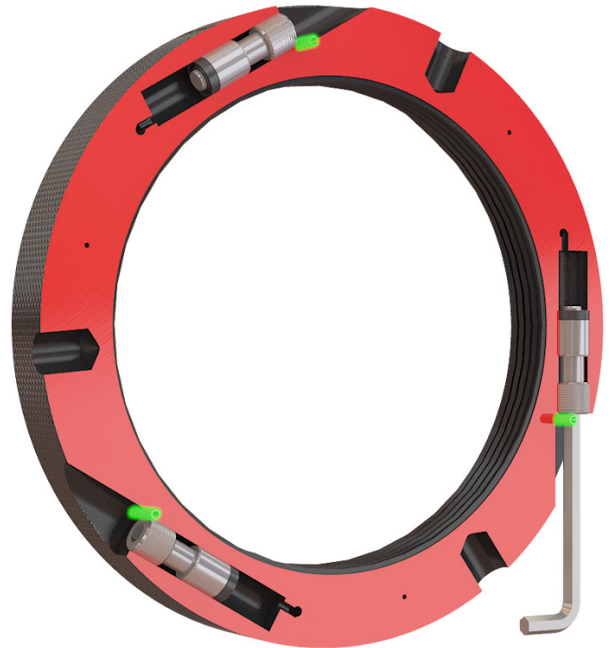



K-Type Nuts

STANDARD SERIES K-6.1 & K-6.2

with RADIALLY LOCATED ACTUATOR SCREW & PISTON

A sealed grease system without pressure release to atmosphere. Actuated by a hand held hex wrench. Transverse pistons provide a narrow profile. Thrust Ring offers 1 or 2 mm of axial travel.

Model	Max Arbor Thread Size		Cannot Exceed Minimum Tool Ø		Verify diameters D & E contact an uninterrupted surface				Select Stroke as Required		Nut Width		Ensure Adequate Force Has Been Selected				Weight	
	Max Thread Ø		Nut Diameter		Thrust Ring Size				Thrust Ring Stroke		Clamping Force							
	A		B		D - OD		E - ID		S		C		10Nm - 89in-lb		20 Nm - 178 in-lb			
	mm	Inch	mm	Inch	mm	Inch	mm	Inch	mm	Inch	mm	Inch	kN	Tons	kN	Tons	KG	Pounds
K-6.104	30	1.125	75	2.953	52	2.047	44	1.732	1	0.039	30	1.181	30	3	60	6	0.9	2.0
K-6.204L	30	1.125	75	2.953	52	2.047	44	1.732	2	0.079	30	1.181	30	3	60	6	0.9	2.0
K-6.106	42	1.625	92	3.622	65	2.559	55	2.165	1	0.039	35	1.378	42	4	84	8	1.5	3.3
K-6.206L	42	1.625	92	3.622	65	2.559	55	2.165	2	0.079	35	1.378	42	4	84	8	1.4	3.1
K-6.107L	52	2.000	112	4.409	84	3.307	72	2.835	1	0.039	36	1.417	66	7	132	13	2.0	4.4
K-6.207L	52	2.000	112	4.409	84	3.307	72	2.835	2	0.079	36	1.417	66	7	132	13	1.9	4.2
K-6.108L	68	2.625	118	4.646	92	3.622	82	3.228	1	0.039	37	1.457	62	6	123	12	2.0	4.4
K-6.208L	68	2.625	118	4.646	92	3.622	82	3.228	2	0.079	37	1.457	62	6	123	12	2.6	5.7
K-6.109L	80	3.125	134	5.276	110	4.331	100	3.937	1	0.039	38	1.496	74	7	148	15	2.7	5.9
K-6.209L	80	3.125	134	5.276	110	4.331	100	3.937	2	0.079	38	1.496	74	7	148	15	2.8	6.2
K-6.210L	100	3.875	167	6.575	125	4.921	110	4.331	2	0.079	45	1.772	83	8	166	17	3.8	8.4
K-6.211L	120	4.750	188	7.402	150	5.906	135	5.315	2	0.079	45	1.772	76	8	152	15	5.5	12.1
K-6.212L	140	5.500	212	8.346	175	6.890	155	6.102	2	0.079	48	1.890	117	12	233	23	7.3	16.1
K-6.213L	160	6.250	230	9.055	200	7.874	180	7.087	2	0.079	50	1.969	90	9	180	18	10.5	23.1
K-6.214L	180	7.000	245	9.646	222	8.740	202	7.953	2	0.079	50	1.969	100	10	200	20	13.0	28.6
K-6.215L	200	7.875	270	10.630	230	9.055	215	8.465	2	0.079	50	1.969	105	11	210	21	10.0	22.0
K-6.216L	220	8.625	290	11.417	255	10.039	235	9.252	2	0.079	50	1.969	115	12	230	23	15.0	33.0
K-6.217L	240	9.375	305	12.008	280	11.024	260	10.236	2	0.079	50	1.969	127	13	254	25	11.0	24.2

*Actual thrust ring force will vary as much as 25% due to actuator thread friction. To obtain accurate setup pressure, please see Series 550 K-Nuts on page 82.

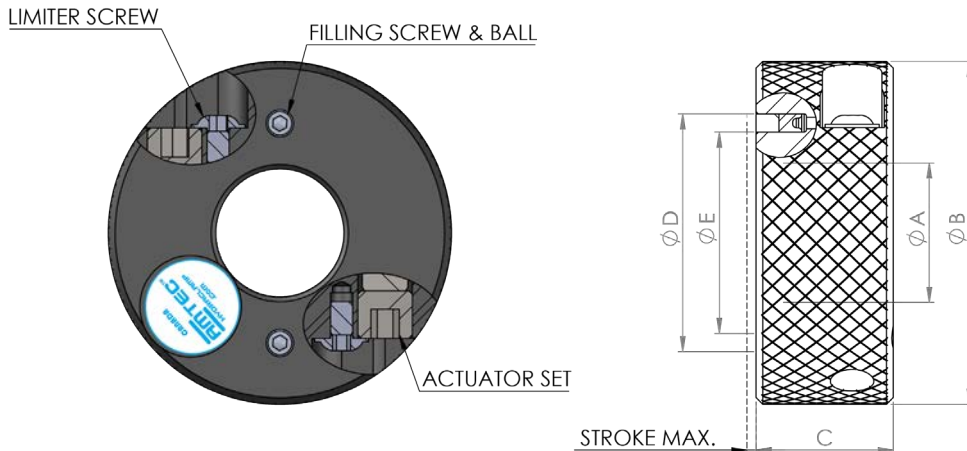



K-Type Nuts

STANDARD SERIES K-7.1, K-7.2 & K-7.4

with AXIAL ACTUATOR SCREW & PISTON

A sealed grease system without pressure release to atmosphere. Actuated by a hand held hex wrench. Axial pistons provide a compact OD. Thrust Ring offers 1 to 4 mm of axial travel.

Model	Max Arbor Thread Size		Cannot Exceed Minimum Tool Ø		Verify diameters D & E contact an uninterrupted surface				Select Stroke as Required		Ensure Adequate Force Has Been Selected				Weight			
	Max Thread Ø		Nut Diameter		Thrust Ring Size				Thrust Ring Stroke		Nut Width		Clamping Force					
	A		B		D - OD		E - ID		S		C		10Nm - 89in-lb		20 Nm - 178 in-lb			
	mm	Inch	mm	Inch	mm	Inch	mm	Inch	mm	Inch	mm	Inch	kN	Tons	kN	Tons	KG	Pounds
K-7.101L	16	0.625	44	1.732	28	1.102	22	0.866	1	0.039	42	1.654	12	1.2	24	2.4	0.4	0.9
K-7.201L	16	0.625	44	1.732	28	1.102	22	0.866	2	0.079	42	1.654	12	1.2	24	2.4	0.4	0.9
K-7.102L	20	0.750	48	1.890	34	1.338	26	1.023	1	0.039	48	1.890	19	2	38	4	0.5	1.1
K-7.202L	20	0.750	48	1.890	34	1.338	26	1.023	2	0.079	48	1.890	19	2	38	4	0.5	1.1
K-7.103L	24	0.875	56	2.205	40	1.574	32	1.260	1	0.039	48	1.890	23	2.3	45	4.5	0.7	1.5
K-7.203L	24	0.875	56	2.205	40	1.574	32	1.260	2	0.079	48	1.890	23	2.3	45	4.5	0.7	1.5
K-7.104L	30	1.125	64	2.520	46	1.811	38	1.496	1	0.039	48	1.890	30	3	60	6	0.9	2.0
K-7.204L	30	1.125	64	2.520	46	1.811	38	1.496	2	0.079	48	1.890	30	3	60	6	0.9	2.0
K-7.105L	36	1.375	70	2.756	52	2.047	44	1.732	1	0.039	48	1.890	30	3	60	6	1.0	2.2
K-7.205L	36	1.375	70	2.756	52	2.047	44	1.732	2	0.079	48	1.890	30	3	60	6	1.0	2.2
K-7.106L	42	1.625	80	3.150	62	2.441	50	1.969	1	0.039	56	2.205	48	5	95	9.5	1.5	3.3
K-7.206L	42	1.625	80	3.150	62	2.441	50	1.969	2	0.079	56	2.205	48	5	95	9.5	1.6	3.5
K-7.107L	52	2.000	90	3.543	72	2.835	60	2.362	1	0.039	62	2.441	56	6	112	11	1.9	4.2
K-7.207L	52	2.000	90	3.543	72	2.835	60	2.362	2	0.079	62	2.441	56	6	112	11	2.0	4.4
K-7.108L	68	2.625	110	4.331	92	3.622	82	3.228	1	0.039	62	2.441	62	6	123	12	2.4	5.3
K-7.208L	68	2.625	110	4.331	92	3.622	82	3.228	2	0.079	62	2.441	62	6	123	12	2.5	5.5
K-7.109L	80	3.125	120	4.724	100	3.937	88	3.465	1	0.039	70	2.756	80	8	160	16	3.2	7.0
K-7.209L	80	3.125	120	4.724	100	3.937	88	3.465	2	0.079	70	2.756	80	8	160	16	3.3	7.3
K-7.210L	100	3.875	148	5.827	125	4.921	110	4.331	2	0.079	80	3.150	83	9	166	17	7.2	15.8
K-7.410L	100	3.875	160	6.299	125	4.921	110	4.331	4	0.157	98	3.858	55	6	110	11	10.0	22.0

*Actual thrust ring force will vary as much as 25% due to actuator thread friction. To obtain accurate setup pressure, please see Series 550 K-Nuts on page 82.

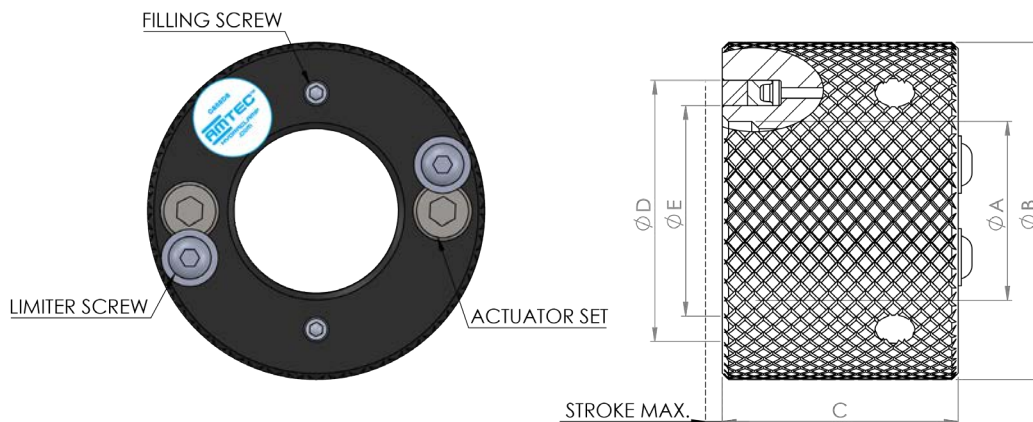



K-Type Nuts

SERIES K-025.XXX.610

with AXIAL ACTUATOR SCREW & PISTON and INDICATOR PIN

A sealed grease system without pressure release to atmosphere. Actuated by a hand held hex wrench. Axial pistons provide a compact OD. Thrust Ring offers 1 to 4 mm of axial travel. Indicator Pin pops up when full nut force is achieved.

Model	Max Arbor Thread Size		Cannot Exceed Minimum Tool Ø		Verify diameters D & E contact an uninterrupted surface				Select Stroke as Required		Nut Width		Ensure Adequate Force Has Been Selected				Weight	
	Max Thread Ø		Nut Diameter		Thrust Ring Size				Thrust Ring Stroke		C		Clamping Force					
	A	B	D - OD	E - ID	S	C	10Nm - 89in-lb	20 Nm - 178 in-lb	KG	Pounds								
	mm	Inch	mm	Inch	mm	Inch	mm	Inch	mm	Inch	mm	Inch	kN	Tons	kN	Tons	KG	Pounds
K-025.075.610	30	1.125	75	2.953	52	2.047	44	1.732	1	0.079	30	1.181	30	3	60	6	0.9	2.0
K-025.088.610	42	1.625	88	3.465	65	2.559	55	2.165	1	0.039	35	1.378	42	4	84	8	1.5	3.3
K-025.112.610	52	2.000	112	4.409	84	3.307	72	2.835	2	0.079	36	1.417	66	7	132	13	1.9	4.2
K-025.118.610	68	2.625	118	4.646	92	3.622	82	3.228	2	0.079	37	1.457	62	6	123	12	2.6	5.7
K-025.134.610	80	3.125	134	5.276	110	4.331	100	3.937	2	0.079	38	1.496	74	7	148	15	2.8	6.2
K-025.167.610	100	3.875	167	6.575	125	4.921	110	4.331	2	0.079	45	1.772	83	8	166	17	3.8	8.4
K-025.188.610	120	4.750	188	7.402	150	5.906	135	5.315	2	0.079	45	1.772	76	8	152	15	5.5	12.1
K-025.212.610	140	5.500	212	8.346	175	6.890	155	6.102	2	0.079	48	1.890	117	12	233	23	7.3	16.1
K-025.230.610	160	6.250	230	9.055	200	7.874	180	7.087	2	0.079	50	1.969	90	9	180	18	10.5	23.1
K-025.245.610	180	7.000	245	9.646	222	8.740	202	7.953	2	0.079	50	1.969	100	10	200	20	13.0	28.6
K-025.270.610	200	7.875	270	10.630	230	9.055	215	8.465	2	0.079	50	1.969	105	11	210	21	10.0	22.0
K-025.290-610	220	8.625	290	11.417	255	10.039	235	9.252	2	0.079	50	1.969	115	12	230	23	15.0	33.0
K-025.305-610	240	9.375	305	12.008	280	11.024	260	10.236	2	0.079	50	1.969	127	13	254	25	11.0	24.2

*Actual thrust ring force will vary as much as 25% due to actuator thread friction. To obtain accurate setup pressure, please see Series 550 K-Nuts on page 82.

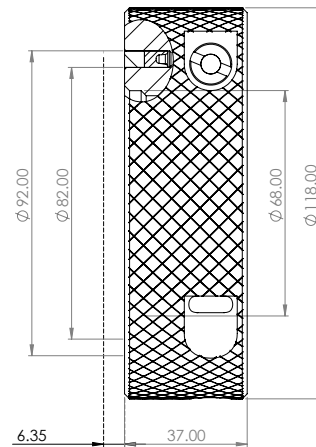
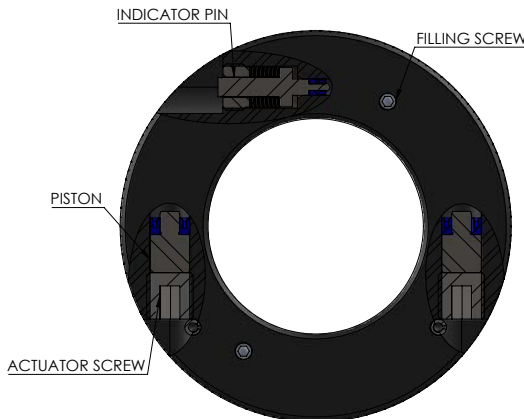



K-Type Nuts

SERIES K-025.XXX.710

with AXIAL ACTUATOR SCREW & PISTON and INDICATOR PIN

A sealed grease system without pressure release to atmosphere. Actuated by a hand held hex wrench. Axial pistons provide a compact OD. Thrust Ring offers 1 to 4 mm of axial travel. Indicator Pin pops up when full nut force is achieved.

Model	Max Arbor Thread Size		Cannot Exceed Minimum Tool \emptyset		Verify diameters D & E contact an uninterrupted surface				Select Stroke as Required		Nut Width		Ensure Adequate Force Has Been Selected				Weight	
	Max Thread \emptyset		Nut Diameter		Thrust Ring Size				Thrust Ring Stroke		C		Clamping Force		Weight			
	A	B	D - OD	E - ID	S	C	10Nm - 89in-lb	20 Nm - 178 in-lb	KG	Pounds								
	mm	Inch	mm	Inch	mm	Inch	mm	Inch	mm	Inch	mm	Inch	kN	Tons	kN	Tons	KG	Pounds
K-025.056.710	24	0.875	56	2.205	40	1.574	32	1.260	2	0.079	48	1.890	23	2.3	45	4.5	0.7	1.5
K-025.064.710	30	1.125	64	2.520	46	1.811	38	1.496	2	0.079	48	1.890	30	3	60	6	0.9	2.0
K-025.070.710	36	1.375	70	2.756	52	2.047	44	1.732	2	0.079	48	1.890	30	3	60	6	1.0	2.2
K-025.080.710	42	1.625	80	3.150	62	2.441	50	1.969	2	0.079	56	2.205	48	5	95	9.5	1.6	3.5
K-025.072.710	52	2.000	90	3.543	72	2.835	60	2.362	2	0.079	62	2.441	56	6	112	11	2.0	4.4
K-025.092.710	68	2.625	110	4.331	92	3.622	82	3.228	2	0.079	62	2.441	62	6	123	12	2.5	5.5
K-025.100.710	80	3.125	120	4.724	100	3.937	88	3.465	2	0.079	70	2.756	80	8	160	16	3.3	7.3
K-025.148.710	100	3.875	148	5.827	125	4.921	110	4.331	2	0.079	80	3.150	83	9	166	17	7.2	15.8
K-025.160.710	100	3.875	160	6.299	125	4.921	110	4.331	4	0.157	98	3.858	55	6	110	11	10.0	22.0

*Actual thrust ring force will vary as much as 25% due to actuator thread friction. To obtain accurate setup pressure, please see Series 550 K-Nuts on page 82.

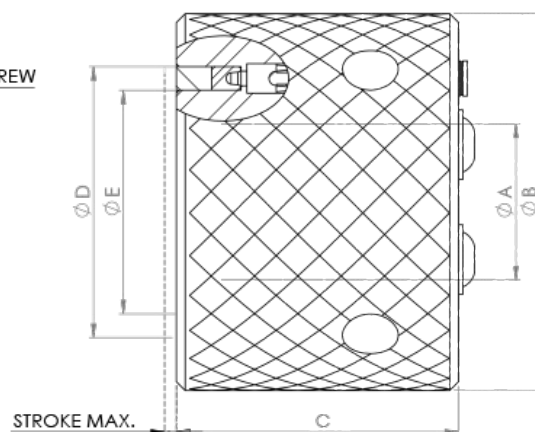
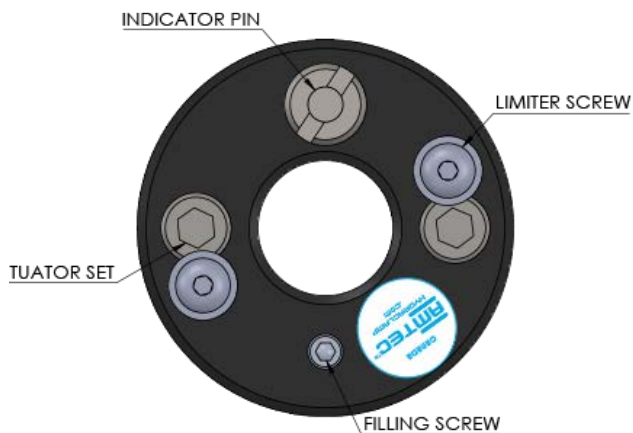



K-Type Nuts

Refill Instructions

The self-contained grease volume within the pressure chamber may gradually leak out and need to be replenished.

** Use only EP1 or EP2 (Calcium Sulphonate) Grease (see page 75 for more information on grease)*

1. Concentrated grease leakage around the thrust ring or the actuator screws would indicate seal failure. The respective sealing system should be replaced before refilling the pressure chamber with grease. See page 39 for spare part information.
2. Remove only one of the two M6 filling screws and the 4 mm ball under the screw (part no. 719.001.006.001), using a 3 mm hex wrench.
3. Support the thrust ring flush with the nut face using a steel plate with a diameter larger than the diameter of the K-Type Nut and clamp in a press. C-clamps or a central bolt and nut arrangement will also work.
4. Insert the hex wrench, as supplied with the nut, into the actuator screw and tighten until the piston bottoms out. This action will expel some grease and possibly air bubbles from the pressure chamber.
5. All actuator screws should be discharged in the same manner as described in number 4 above.
6. Screw a filler nipple with M6 thread (part no. 710.101.006.010) into the open filling screw hole and hand tighten with a wrench.
7. Remove the second M6 filling screw and the 4mm ball underneath.



8. Apply a handpump to the nipple and then pump grease through the nut until the grease exiting the open filling screw hole is clean and free from air bubbles. Remove the handpump.
9. Replace the 4 mm ball and the M6 filling screw into the open filling screw hole and tighten the screw with the 3 mm hex wrench.
10. Apply a handpump to the filler nipple again and pump grease into the nut to just indicate a slight pressure. While maintaining slight pressure, gradually return one actuator screw to a flush position against the limit screw on the counter-bore for K-6 Type Nuts or with the end face of the nut on K-7 Type Nuts.
11. Additional actuator screws should be returned to the flush position, under slight pressure, as described above.
12. Remove the handpump from the filler nipple, unscrew the filler nipple and replace the 4 mm ball and M6 filling screw. Hand tighten with the 3 mm hex wrench.
13. Refill is complete. Test the Amtec K-Type Nut under working conditions.
14. Contact your local Amtec Distributor, or Amtec Hydraclamp directly, for repair service or genuine Amtec Hydraclamp repair parts.



K-Type Nuts

Spare Parts Replacement Instructions

K-Type Nuts are pressurized through the tightening of their actuator assemblies located on the end face (axial surface) or on the OD (radial surface) of the nut by a hex wrench.

1. Amtec repair kits (series 714) contain all components for a complete K-Type Nut rebuild; each model has a specific kit number.
2. Remove only one of the two M6 filling screws and the 4 mm ball under the screw (part no. 719.001.006.001), using a 3 mm hex wrench.
3. Support the thrust ring flush with the nut face using a steel plate with a diameter larger than the diameter of the K-Type Nut and clamp in a press. C-clamps or a central bolt and nut arrangement will also work.
4. Screw a filler nipple with M6 thread (part no. 710.101.006.010) into the open filling screw hole and hand tighten with a wrench.
5. Remove the actuator screw (hex socket set screw) from one piston assembly.
6. Apply handpump to the filler nipple and pump grease into the nut until the piston and seal come out of the nut. If the piston comes out without the seal, use a cotton swab and a clean non-metallic probe to remove the seal and remaining grease. (DO NOT USE SOLVENT)
7. If more than one piston seal requires replacement, then re-install the actuator screw only into the piston bore just completed to retain grease pressure. Repeat step 6 for second (or third) piston removal.
8. Inspect the piston bores to ensure there is no scoring and all dirt particles have been removed. Scrap the nut if scoring has cut the seal lip.
9. Fill the U-cup face of each piston seal with clean grease and apply a thin coat of grease on the piston bore. Insert the seal by hand, sideways past the threaded area. Using a clean, non-metallic probe, turn the seal so the lips of the seal are resting flat on the bottom of the piston bore. Lay the 1 mm thick scuff ring flat on top of the seal.
10. Insert the new piston with the pin projection toward seal. Using a clean non-metallic dowel, tap the piston firmly to insert the pin projection through the scuff ring and seal. A metallic sound will be heard as the pin projection strikes the bottom of the piston bore.
11. Insert the new actuator screw and hand tighten with the hex wrench provided.
12. Upon completion of the installation of all piston assemblies, remove the second filling screw and 4 mm ball using a 3 mm hex wrench.
13. Apply a handpump to the filler nipple and pump grease through the nut until the grease exiting from the open filling screw hole is clean and free from air bubbles. Remove the handpump.
14. Replace the 4 mm ball and the M6 filling screw into the open filling screw hole and tighten the screw with the 3 mm hex wrench.
15. Apply a handpump to the filler nipple again and pump grease into the nut to just indicate a slight pressure. While maintaining slight pressure, gradually return one actuator screw to a flush position on the counter-bore for K-6 Type Nuts or with the end face of the nut on K-7 Type Nuts.
16. Additional actuator screws should be returned to the flush position, under slight pressure, as described above.
17. To ensure all air bubbles have been purged from the grease chamber, again remove the second M6 Filling Screw and 4 mm ball.
18. Tighten all actuator screws until the pistons stop moving and the grease and any air bubbles have exited the filling screw hole.
19. Apply a handpump to the filler nipple and pump grease through the nut until the grease emission (EP1) from the open filling screw hole is clean and free of air bubbles. Remove the handpump and repeat steps 14, 15, and 16.
20. Remove the handpump from the filler nipple, unscrew the filler nipple and replace the 4 mm ball and M6 filling screw. Hand tighten with the 3 mm hex wrench.
21. Refill is complete. Test the Amtec K-Type Nut under working conditions.
22. Contact your local Amtec agent or Amtec direct, for rebuild service or genuine Amtec repair kits.

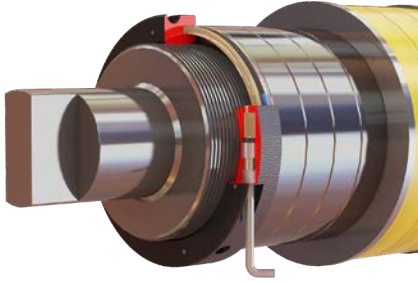

K-Type Nuts

Operating Instructions

K-Type Nuts are pressurized by tightening one or more actuator screws located on the end face or on the radial surface of the nut, by a hand held hex wrench.

A. To Install Nuts and Apply Pressure

1. Clean the threads and contact faces of the K-Type Nuts, arbors and mating tooling.
2. Pack all tooling solidly together on the arbour before installing the K-Type Nuts.
3. With K-Series Nuts, the actuator screws must be unscrewed until flush with the limit screws, which prevents retraction past flush.
4. With older K-Series Nuts, the actuator screws must be unscrewed until they are flush with the axial face (K-7 Series) or contact the roll pin (K-6 Series).
5. If the thrust ring sits proud, tighten the K-Type Nut with an Amtec Assist Bar to retract by hand until the thrust ring contacts the mating tooling. Continue to tighten the K-Type Nut to retract the thrust ring until it is flush with the nut face.
6. Loosen the K-Type Nut 10 or 20 degrees to provide a slight clearance between the thrust ring and the contact face on the tooling. This step is extremely important to prevent the nut from binding upon removal.
7. Insert the hex wrench, as supplied with the nut, into the actuator screw and tighten by hand. Although "hand tight" is generally sufficient, refer to the "Clamping Force vs Actuator Torque" column in the K-6 or K-7 product page for torque specifications, if required.

B. To Release Pressure and Remove Nuts

1. Insert the hex wrench, as supplied with the nut, into the actuator screw and turn to the left until the actuator screws are flush with the limit screw, or as per A4 above, for older nuts.
2. Insert the assist bar (page 76) in the radial holes of the nut to tighten the K-Type Nut against the mating tooling to compress the thrust ring into the nut body. This protects the thrust ring from damage and prepares the nut for subsequent use.
3. Remove the K-Type Nut from the arbor and place on a wooden bench to prevent damage to the nut face.
4. Tooling may now be removed.

C. Remarks

1. DO NOT tighten the actuator screws when the nuts are off line. The thrust ring has no retainer, and can be forced out of the pressure chamber, causing distortion of the thrust ring and possible rupture of the sealing system.
2. Use only genuine Amtec Hydraclamp repair parts to guarantee clamping reliability.
3. DO NOT remove the limit screws and unscrew the actuator screws beyond their reference faces, as described in Section A, above. Doing so may damage the seals of the actuator assembly.
4. Respect the designed thrust ring maximum stroke (S max) for the particular K-Type Nut being used. Excess travel can cause the seals to rupture, which may cause physical damage.

D. Service

1. For service and spare parts contact your local distributor or call Amtec Hydraclamp directly.

Amtec Hydraclamp Thread Builder Code

Amtec Hydraclamp offers all standard machine threads on the market. See page 7 for more details on threads. Amtec Hydraclamp requires the thread form, diameter, pitch and rotation direction at time of order. Below is the Amtec Hydraclamp how to order code for thread information.

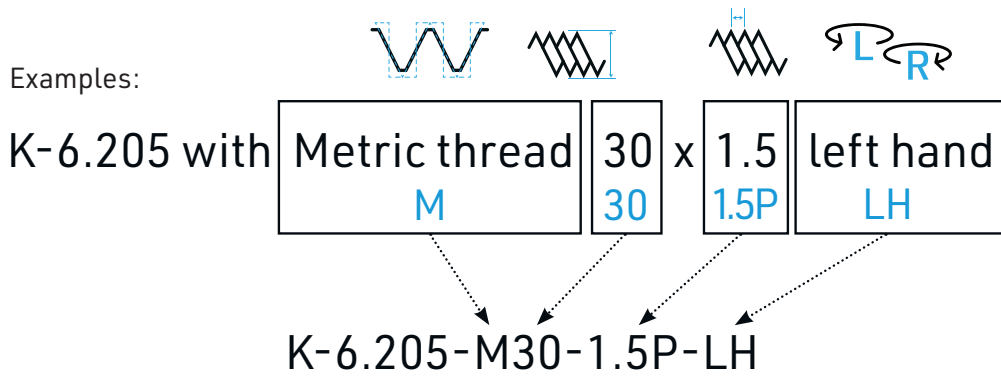
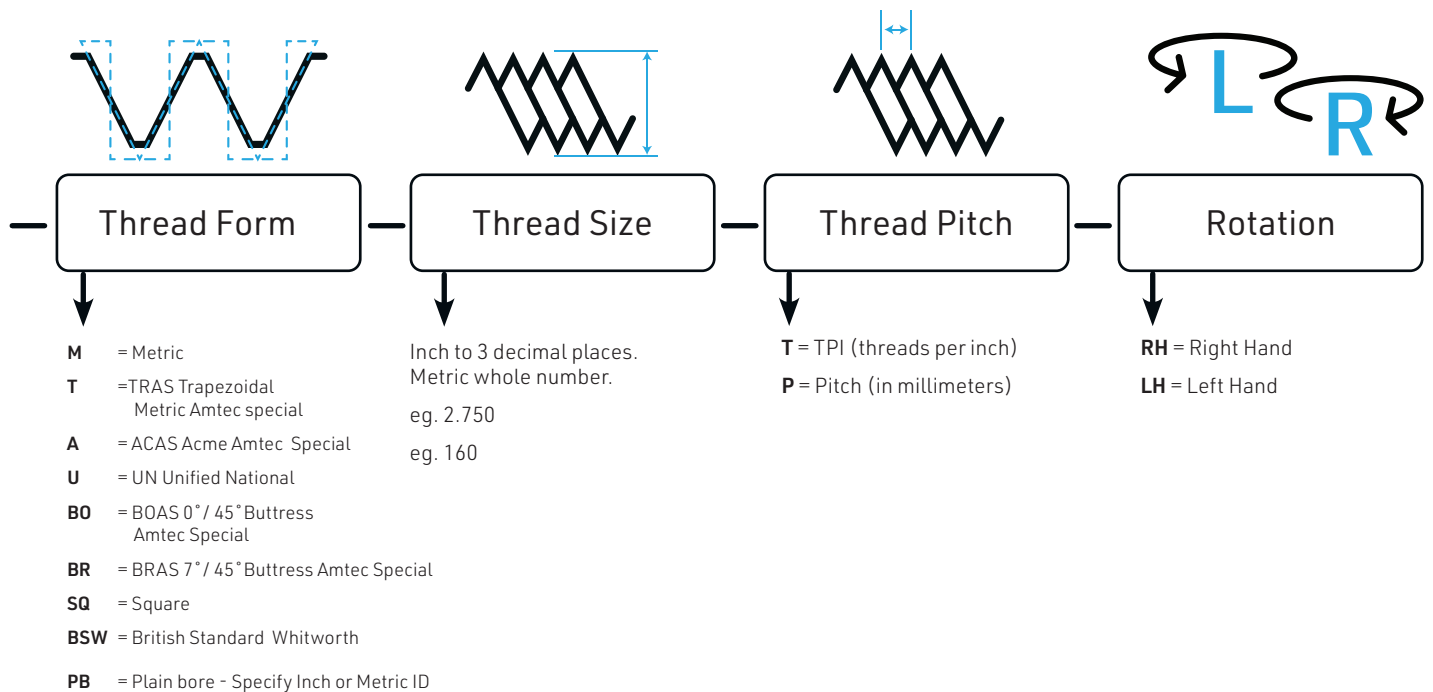

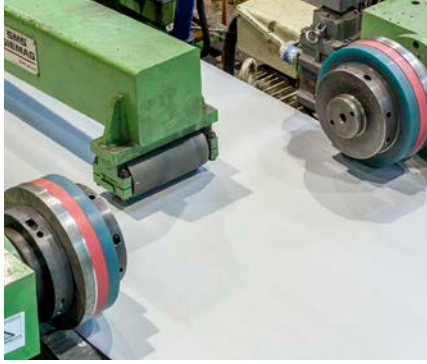

Side Trimmer Nuts

Amtec Sider Trimmer Nuts are a standard series of hydraulic nuts commonly used for heavy duty side trimmer applications. These K-Series piston activated hydraulic nuts with indicator pins are the newest revisions to the K-531 series nut they replace.

Used primarily on the Top Arbor Inboard, Top Arbor Outboard and Bottom Arbor Outboard locations, Amtec stocks these nuts with their standard metric trapezoidal thread configurations.

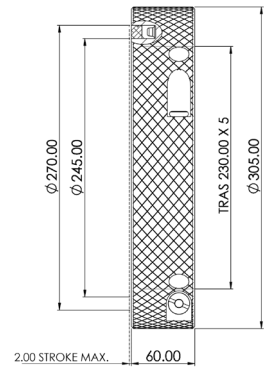
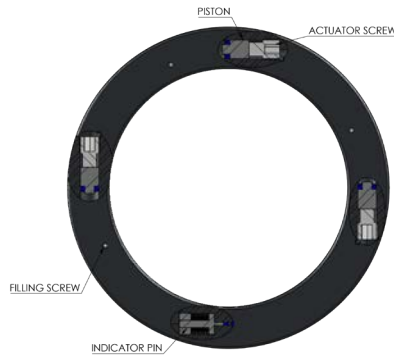

DWG Number: 22405314

Old Part Number: K-531.305.610N

New Part Number: K-025.305.610

Thread: T230 X 5P RH

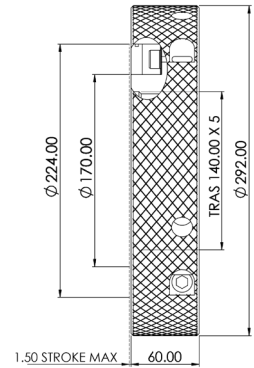
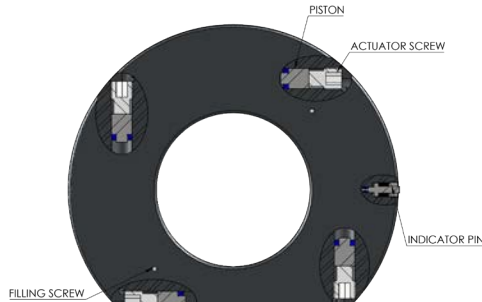

DWG Number: 22405331

Old Part Number: K-531.292.610N

New Part Number: K-612.292.625

Thread: T140 X 5P RH

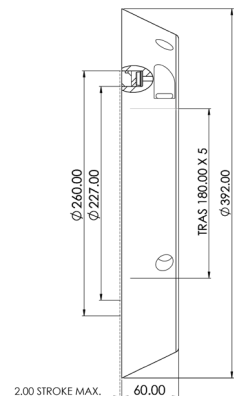
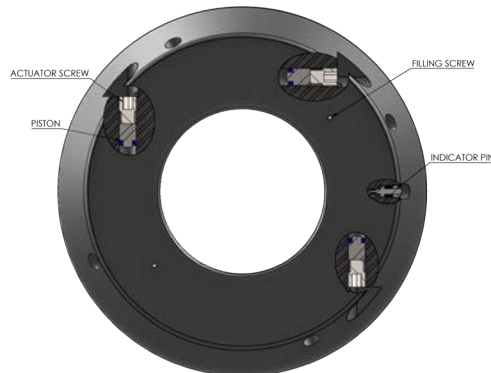

DWG Number: 22405325

Old Part Number: K-531.292.620N

New Part Number: K-229.392.625

Thread: T180 X 5P RH

K-Type Nuts Accessories



Amtec Assist Bars

Part Number: 801.101.***.***

Install and remove nuts with ease.

See page 76 for details.



Amtec High-Pressure Handpumps

Part Number: 112.100.200-*** and 112.110.210-***

The best handpump in the industry;
rated for over 1000 bar.

See page 66 for details.

Grease Tube Cartridges

Part Number: 801.200.002

Also available in buckets and drums.

See page 77 for details.



Replacement Parts

Replacements parts are
available for all K-Type Nuts.

Contact Amtec
Hydraclamp or your
location distributor for
more information.





GX-Nuts

Amtec Hydraclamp™ Heavy Duty Hydraulic Nuts are suitable for extreme applications requiring high clamping force and rapid setup speed. GX-Nuts are suitable for casters, gearbox and pinion stands, plate mill side trimmers and tube mills.

Amtec Hydraulic Nuts safely and conveniently replace major mechanical nuts on all types of metal processing lines by eliminating sledge hammers and heavy wrenches, which cause much of the strain and physical injury to the set-up personnel. Bearing and bolt damage from hammering nuts is eliminated with GX-Type Hydraulic Nuts. By using Amtec High Pressure Oil Handpumps or Hydraulic Power Units to pressurize the Amtec Nuts, positive, controlled clamping force ensures reliably accurate tooling set-ups with every installation. 100% of all effort to pressurize GX-Type Nuts is converted to clamping force, eliminating friction on threads, which is the prime cause of early thread wear.

All Amtec GX-Type Nuts are activated by oil to suit operating specifications. Amtec GX-Type Nuts offer self-aligning, annular thrust rings that create a high force lock to prevent unthreading once pressure is applied.

The extreme internal pressure pushes the thrust ring against the mating tooling and simultaneously forces the nut body to locate against the plate, bearing or shaft threads. Therefore, all threads may be right hand rotation regardless of whether an arbor or shaft rotation is clockwise or counterclockwise. Amtec will custom manufacture all GX-Type Nuts to any existing thread form, regardless of thread hand, provided the thread form conforms to international standards.

To compensate for increased weight in larger sized nuts, we offer aircraft grade aluminum nut models at half the weight of our standard high strength steel. Comparable durability, performance and quality are guaranteed with all aluminum nuts, although maximum pressure is reduced from 700 bar to 400 bar.

Amtec GX-Type Nuts are manufactured from 4140 chromoly steel or QC-10 aircraft aluminum.



FEATURES:

- Standard black oxide finish for 120°C max. (250°F)
- Special finishes for service up to 240°C max. (460°F)
- 4140 alloy tool steel or QC-10 aircraft aluminum body parts
- Stainless steel, electroless nickel or chromium plating for optional corrosion resistance
- Unidirectional, all steel, high pressure GX-Nipple
- All components rated at 840 bar max. (12,180 psi)
- Aluminum nuts are half the weight of steel

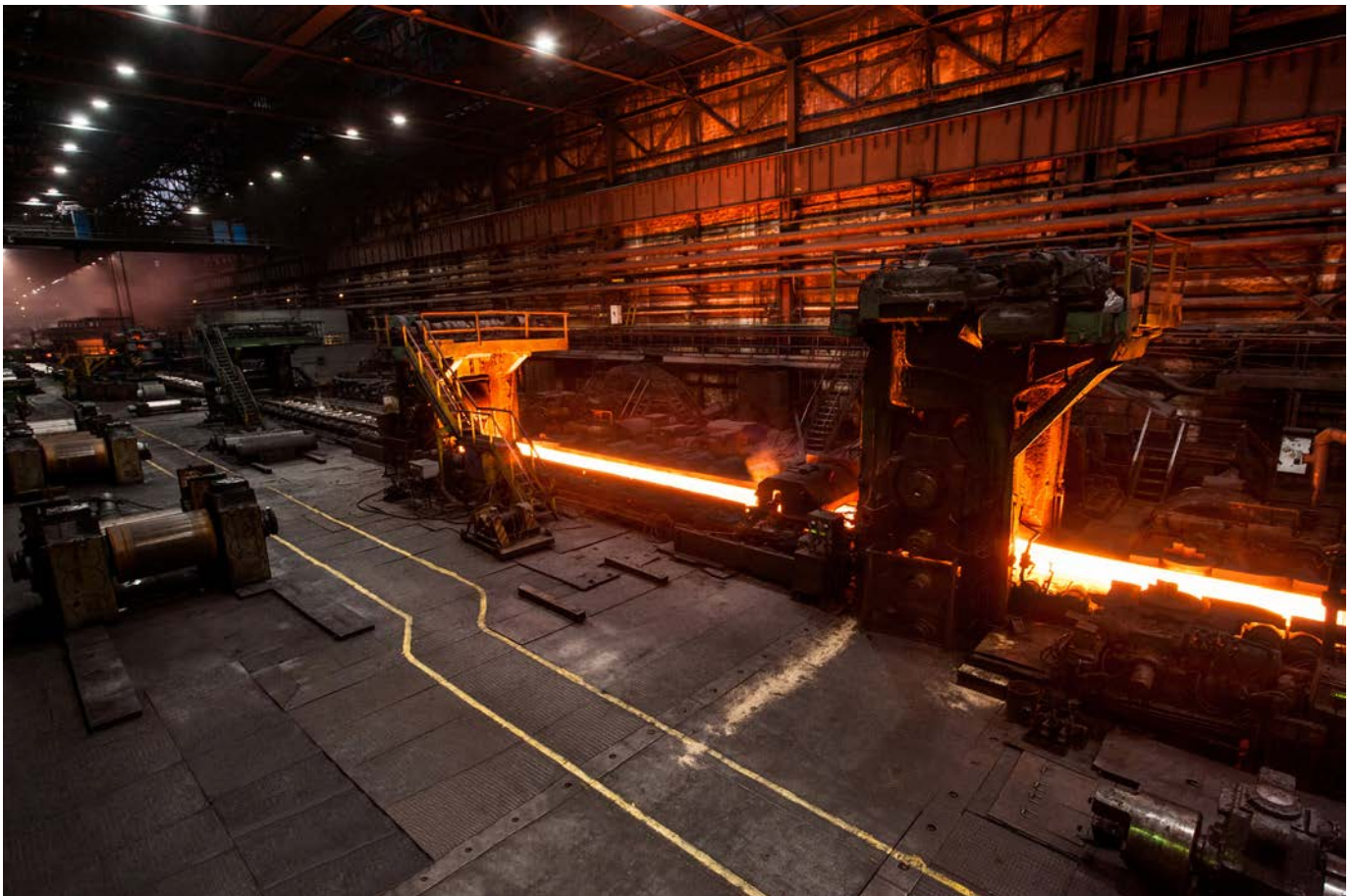



GX-Type Nuts

SERIES GX-4.4 & GX-4.10

with RADIALLY LOCATED GX-NIPPLE

Actuated by hydraulic power unit or manual oil pump. Self-aligning annular thrust ring with 4 or 10 mm maximum axial travel.

Model	Max Arbor Thread Size		Cannot Exceed Minimum Tool Ø		Verify diameters D & E contact an uninterrupted surface				Select Stroke as Required		Nut Width		Ensure Adequate Force Has Been Selected				Weight*	
	Max Thread Ø		Nut Diameter		Thrust Ring Size				Thrust Ring Stroke		Nut Width		Clamping Force					
	A	B	D - OD		E - ID		S		C		400 BAR	700 BAR	KG	LBS				
	mm	Inch	mm	Inch	mm	Inch	mm	Inch	mm	Inch	mm	Inch	kN	Tons	kN	Tons	KG	LBS
GX-4.415	198	7.875	272	10.709	240	9.449	215	8.465	4	0.157	65	2.559	357	40	625	70	15.3	33.7
GX-4.1015	198	7.875	272	10.709	240	9.449	215	8.465	10	0.394	80	3.150	357	40	625	70	16.0	35.2
GX-4.415.5	202	7.875	290	11.417	260	10.236	235	9.252	4	0.157	65	2.559	389	43	680	76	16.0	35.2
GX-4.1015.5	202	7.875	290	11.417	260	10.236	235	9.252	10	0.394	65	2.559	389	43	680	76	20.0	44.0
GX-4.416	210	8.250	306	12.047	272	10.709	240	9.449	4	0.157	65	2.559	428	58	749	101	18.0	39.6
GX-4.10165	210	8.250	306	12.047	272	10.709	240	9.449	10	0.394	80	3.150	428	58	749	101	18.0	39.6
GX-4.417	230	9.000	319	12.559	285	11.220	260	10.236	4	0.157	65	2.559	428	48	749	84	21.5	47.3
GX-4.1017	228	9.000	320	12.598	285	11.220	260	10.236	10	0.394	80	3.150	428	48	749	84	22.5	49.5
GX-4.418	248	9.750	345	13.583	310	12.205	280	11.024	4	0.157	70	2.756	556	62	973	109	25.0	55.0
GX-4.1018	248	9.750	345	13.583	310	12.205	280	11.024	10	0.394	80	3.150	556	62	973	109	26.0	57.2
GX-4.419	268	10.500	365	14.370	330	12.992	300	11.811	4	0.157	75	2.953	556	67	973	109	31.0	68.2
GX-4.1019	268	10.500	365	14.370	330	12.992	300	11.811	10	0.394	80	3.150	556	67	973	109	32.0	70.4
GX-4.4195	292	11.500	394	15.512	355	13.976	325	12.795	4	0.157	75	2.953	640	71	1121	125	30.8	67.8
GX-4.10195	292	11.500	394	15.512	355	13.976	325	12.795	10	0.394	80	3.150	640	71	1121	125	31.8	70.0
GX-4.420	298	11.750	408	16.063	366	14.409	330	12.992	4	0.157	80	3.150	787	88	1377	154	40.0	88.0
GX-4.1020	298	11.750	408	16.063	366	14.409	330	12.992	10	0.394	85	3.346	787	88	1377	154	41.0	90.2
GX-4.1021	324	12.750	448	17.638	400	15.748	360	14.173	10	0.394	85	3.346	955	107	1671	187	43.0	94.6
GX-4.1022	356	14.000	466	18.346	422	16.614	390	15.354	10	0.394	85	3.346	816	91	1428	160	45.0	99.0
GX-4.1023	382	15.000	494	19.449	450	17.717	420	16.535	10	0.394	85	3.346	820	92	1428	161	54.0	118.8
GX-4.1024	420	16.500	548	21.575	500	19.685	460	18.110	10	0.394	85	3.346	1206	135	2110	237	92.0	202.4
GX-4.1025	452	17.750	568	22.362	520	20.472	490	19.291	10	0.394	90	3.543	952	107	1665	187	94.0	206.8

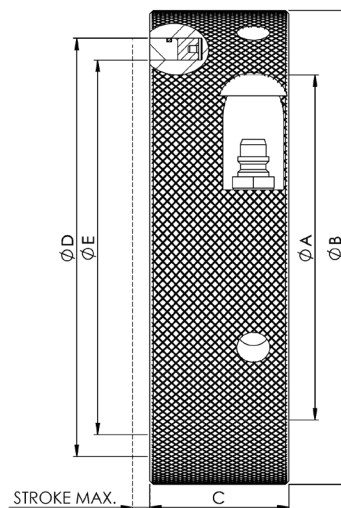

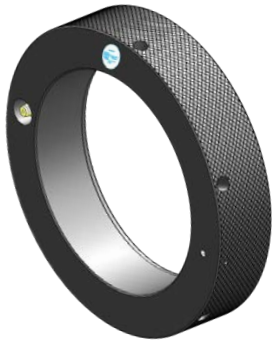

GX-Type Nuts

SERIES GX-5.4 & GX-5.10

with AXIALLY LOCATED GX-NIPPLE

Actuated by hydraulic power unit or manual oil pump. Self-aligning annular thrust ring with 4 or 10 mm maximum axial travel.

Model	Max Arbor Thread Size		Cannot Exceed Minimum Tool Ø		Verify diameters D & E contact an uninterrupted surface				Select Stroke as Required		Nut Width		Ensure Adequate Force Has Been Selected				Weight*	
	Max Thread Ø		Nut Diameter		Thrust Ring Size				Thrust Ring Stroke		C		400 BAR		700 BAR			
	A		B		D - OD		E - ID		S				kN	Tons	kN	Tons	KG	LBS
	mm	Inch	mm	Inch	mm	Inch	mm	Inch	mm	Inch	mm	Inch						
GX-5.415	198	7.875	272	10.709	240	9.449	215	8.465	4	0.157	75	2.953	357	40	625	70	15.3	33.7
GX-5.1015	198	7.875	272	10.709	240	9.449	215	8.465	10	0.394	75	2.953	357	40	625	70	16.0	35.2
GX-5.415.5	202	7.875	290	11.417	260	10.236	235	9.252	4	0.157	75	2.953	389	43	680	76	16.0	35.2
GX-5.1015.5	202	7.875	290	11.417	260	10.236	235	9.252	10	0.394	75	2.953	389	43	680	76	20.0	44.0
GX-5.416	210	8.250	306	12.047	272	10.709	240	9.449	4	0.157	75	2.953	428	58	749	101	18.0	39.6
GX-5.10165	210	8.250	306	12.047	272	10.709	240	9.449	10	0.394	80	3.150	428	58	749	101	18.0	39.6
GX-5.417	230	9.000	319	12.559	285	11.220	260	10.236	4	0.157	75	2.953	428	48	749	84	21.5	47.3
GX-5.1017	228	9.000	320	12.598	285	11.220	260	10.236	10	0.394	80	3.150	428	48	749	84	22.5	49.5
GX-5.418	248	9.750	345	13.583	310	12.205	280	11.024	4	0.157	75	2.953	556	62	973	109	25.0	55.0
GX-5.1018	248	9.750	345	13.583	310	12.205	280	11.024	10	0.394	80	3.150	556	62	973	109	26.0	57.2
GX-5.419	268	10.500	365	14.370	330	12.992	300	11.811	4	0.157	75	2.953	556	67	973	109	31.0	68.2
GX-5.1019	268	10.500	365	14.370	330	12.992	300	11.811	10	0.394	80	3.150	556	67	973	109	32.0	70.4
GX-5.4195	292	11.500	394	15.512	355	13.976	325	12.795	4	0.157	75	2.953	640	71	1121	125	30.8	67.8
GX-5.10195	292	11.500	394	15.512	355	13.976	325	12.795	10	0.394	80	3.150	640	71	1121	125	31.8	70.0
GX-5.420	298	11.750	408	16.063	366	14.409	330	12.992	4	0.157	80	3.150	787	88	1377	154	40.0	88.0
GX-5.1020	298	11.750	408	16.063	366	14.409	330	12.992	10	0.394	85	3.346	787	88	1377	154	41.0	90.2
GX-5.1021	324	12.750	448	17.638	400	15.748	360	14.173	10	0.394	85	3.346	955	107	1671	187	43.0	94.6
GX-5.1022	356	14.000	466	18.346	422	16.614	390	15.354	10	0.394	85	3.346	816	91	1428	160	45.0	99.0
GX-5.1023	382	15.000	494	19.449	450	17.717	420	16.535	10	0.394	85	3.346	820	92	1428	161	54.0	118.8
GX-5.1024	420	16.500	548	21.575	500	19.685	460	18.110	10	0.394	85	3.346	1206	135	2110	237	92.0	202.4
GX-5.1025	452	17.750	568	22.362	520	20.472	490	19.291	10	0.394	90	3.543	952	107	1665	187	94.0	206.8

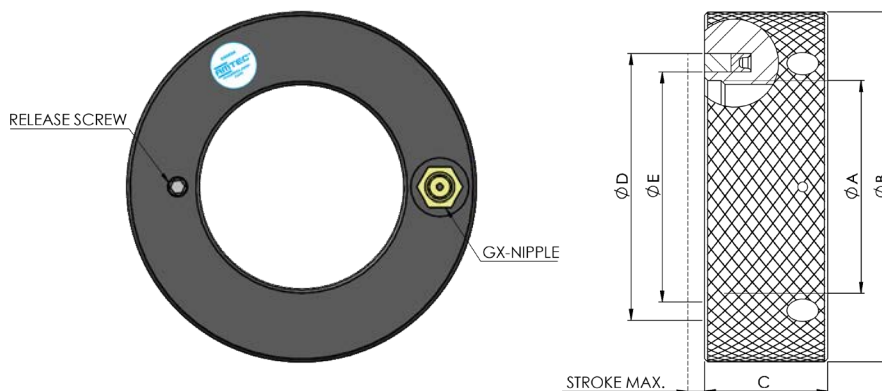

Like all Amtec Hydraclamp nuts, we will happily manufacture GX-Type Nuts with aircraft aluminum. GX-Type Nuts are our largest design, and because aluminum nuts are half the weight as our 4140 steel versions, your mass savings are significant. If you require a nut size outside of what you see above, Amtec Hydraclamp will accommodate. We make smaller GX-Type Nuts for custom requirements, but also have the capacity to produce these clamps over 750mm (30.0") OD.



GX-Type Nuts

Operating Instructions

Pressurize GX-Type Nuts directly using hydraulic handpumps or hydraulic power units. Amtec Hydraclamp GX-Nipple and GX-Coupler high-pressure oil connections are required.

A. Bleeding the Nut

1. Amtec GX-Type Nuts are shipped either fully charged with hydraulic oil, or dry, depending on the design. Through transportation, handling or refilling, air may have been drawn into the pressure chamber of the nut. As with all hydraulic systems, air bubbles must be bled from the nut prior to operation to ensure reliable clamping forces.
2. Clean the threads and contact faces of the GX-Type Nuts, arbors and/or mating tooling. Ensure all tooling is packed solidly together, ready for clamping.
3. Assemble the GX-Nut onto the intended arbor and manually tighten against a continuous counter face, then back-off until the vent screw is in the 12 o'clock position.
4. Open the vent screw on the GX-Nut one full turn using the 6 mm hex wrench provided.
5. Connect the GX-Coupler from the oil pump to the GX-Nipple on the nut (please see website for more details).
6. When using the Amtec Handpump series 114.427.***, rotate the 2-way control valve clockwise until it stops in the "clamp" position.
7. Pump oil at minimum pressure into the GX-Nut until oil flows around the vent screw without air bubbles.
Note: keep pressure to a minimum to ensure that the thrust ring is not pushed out.
8. Close the vent screw hand tight, using the 6 mm hex wrench provided, and remove the GX-Coupler from the GX-Nipple by pulling back on the retraction sleeve on the GX-Coupler.
9. Hand tighten the GX-Nut until the thrust ring touches the tooling counter face and check that the thrust ring is also flush with the end face of the nut body.
10. If the thrust ring is not flush with the nut body, reconnect the GX-Coupler to the GX-Nipple, as in Section A, step 5, above. Once the GX-Coupler is securely connected to the GX-Nipple, then rotate the actuator lever on the GX-Coupler to rest against the steel pin. This procedure activates the valve pin in the GX-Coupler, which opens the GX-Nipple to oil passage. Tighten the GX-Nut, using an assist bar in one of the peripheral assist bar holes, until the thrust ring is flush with the end face of the nut body. Excess oil from inside the GX-Nut has been expelled into the pump reservoir.
11. Loosen the GX-Nut 10 to 20 degrees to ensure that only the thrust ring will clamp the tooling when energized, which will provide for easy release of the nut later. Remove the assist bar.
12. Remove the GX-Coupler from the GX-Nipple by pulling back on the retractions sleeve on the GX-Coupler.
13. The GX-Nut is now ready for pressurizing.

B. Install Nuts and Apply Pressure

1. Clean the threads and contact faces of the GX-Type Nuts, arbors and mating tooling. Ensure that all tooling is packed solidly together on the arbor ready for clamping.
2. Assemble the GX-Type Nuts onto the arbors and tighten by hand against the mating tooling. Ensure that the thrust ring is flush with the face of the Amtec Nut.
3. If the thrust ring is not flush with the face of the Amtec Nut then follow steps 10 through 13, Section A, page 44.
4. Loosen the GX-Nut 10 to 20 degrees to ensure that only the thrust ring will clamp the tooling when energized, which will provide for easy release of the nut later. Remove the assist bar.
5. Ensure that the vent screw is hand tight using the 6 mm hex wrench provided.
6. Wipe the end face of the GX-Nipple with a clean thumb to ensure that dirt is not pumped into the nut.
7. Apply the GX-Coupler and operate the handpump. Please see website for more details covering Amtec oil handpumps operating instructions.
8. The GX-Nut is now fully pressurized and ready for operation.



C. Release Pressure and Remove Nuts

1. Wipe the end face of the GX-Nipple with a clean thumb to ensure that dirt is not pumped into the nut.
2. Apply the GX-Coupler and operate the handpump. Please see website for more details on handpumps operation instructions.
3. Since GX-Type Nuts are single acting hydraulic systems, the thrust ring must be manually retracted to the home position. To accomplish this, leave the GX-Coupler in place, insert an assist bar into one of the peripheral assist bar holes in the nut body and tighten the nut onto the arbor until the thrust ring is flush with the end face of the nut body. With the assist bar still in the assist bar hole, loosen the nut 10 to 20 degrees, then remove the bar. All excess oil inside the pressure chamber has been sent to the reservoir.
4. Pull back on the retraction sleeve on the GX-Coupler and remove the coupler from the GX-Nipple.
5. The GX-Nut is now fully de-pressurized and ready for removal by hand.

D. Remarks

1. Do not apply pressure to the GX-Type Nuts when they are off-line. The thrust ring has no retainer and can be forced out of the pressure chamber causing distortion of the thrust ring and possible rupture of the seal.
2. Use only genuine Amtec GX-Nipples, vent screws, seals, thrust rings and handpumps to guarantee clamping reliability.
3. Use only ISO VG 22 or 32 hydraulic oil in the pump reservoir. Keep reservoir cap in place to eliminate dirt and dust.

E. Service

1. For service and spare parts contact your local distributor or Amtec Hydraclamp Inc. directly.



GX-Type Nuts

GX-Type Nuts work well with our Series 550 Pressure Transponders. Now, you don't have to guess if your hydraulic nuts are holding pressure. Simply place the reader near the wireless pressure sensor, and with the press of a button, your nut pressure is known.

See page 80 for more details. on the Series 550 Pressure Transponder.



GX-Type Nuts Accessories



Amtec Assist Bars

Part Number: 801.101.***.***

Install and remove nuts with ease.

See page 76 for details.

GX-Couplers & GX-Nipples

Rated for over 1000 bar (14,500 PSI)

Connects pumps or oil activated nuts, even under pressure.

See page 78 for details.



Replacement Parts

Replacement parts are available for all GX-Nuts.

Contact Amtec your local distributor for more informations.



High-Pressure Handpumps

These reliable, high pressure pumps come in 250, 400 and 700 bar pressure ranges Operates H-nuts or GX-nuts. Custom options available.

See page 66 for details.



H-Nuts

Amtec Hydraclamp™ Hydraulic Clamping Nuts are suitable for cross cut shears, choppers and utilities, which all benefit from the exceptional safety, convenience, efficiency and highly controllable clamping.

Amtec Hydraulic Nuts safely and conveniently replace major mechanical nuts on all types of metal processing line shears. It eliminates sledgehammers and heavy wrenches, which cause much of the strain and physical injury to the set-up personnel. By using Amtec high-pressure handpumps or high-pressure power units to pressurize Amtec H-Type nuts, positive, controlled clamping force is applied with every installation to ensure reliably accurate tooling set-ups. Amtec's Rapid Shear Knife Change-Over system secures shear blades firmly while allowing exceptionally quick knife replacement.

100% of all effort to pressurize Amtec Hydraulic Nuts is converted to clamping force, eliminating friction on threads, which is the prime cause of early thread wear. All Amtec H-Type Nuts can activate with hydraulic pressure to suit operating specifications. Amtec H-Type Nuts offer self-aligning, annular thrust rings, which create a high force lock to prevent unthreading once pressure is applied. The extreme internal pressure pushes thrust rings against the mating tooling and simultaneously forces the nut body to locate against the arbor or shaft threads. Therefore, all threads may be right hand regardless of whether the arbor or shaft rotation is clockwise or counterclockwise. Amtec customizes all H-Type Nuts to any existing thread form, regardless of thread hand, provided the thread form conforms to international standards.

We offer aircraft-grade aluminum nut models at 40-50% the weight of our standard high strength steel to compensate for increased weight in larger sized nuts. Comparable durability, performance and quality are guaranteed with all-aluminum nuts, although we reduce maximum pressure from 700 bar to 400 bar. Precise tolerance control on all equipment is critical under current market conditions. We manufacture Amtec H-Type Nuts from 4140 chromoly steel or QC-10 aircraft aluminum.



FEATURES:

- Standard black oxide finish for 120°C max. (250°F)
- Special finishes for service up to 240°C max. (460°F)
- Alloy tool steel body parts
- Stainless steel, electroless nickel or chromium plating for optional corrosion resistance
- BSPP or SAE O-ring boss ports
- All components rated at 840 bar max. (12,180 psi)
- Aluminum nuts are half the weight as steel





H-Type Nuts

SERIES H-2.4 & H-2.10

with TRANSVERSE FLUID PORTS

Actuated by manual oil pump or hydraulic power unit. Self-aligning annular thrust ring with 4 or 10 mm maximum axial travel.

Model	Max Arbor Thread Size		Cannot Exceed Minimum Tool Ø		Verify diameters D & E contact an uninterrupted surface				Select Stroke as Required		Nut Width		Ensure Adequate Force Has Been Selected				Weight	
	Max Thread Ø		Nut Diameter		Thrust Ring Size				Thrust Ring Stroke		C		400 BAR		700 BAR		KG	LBS
	A		B		D - OD		E - ID		S									
	mm	Inch	mm	Inch	mm	Inch	mm	Inch	mm	Inch	mm	Inch	kN	Tons	kN	Tons		
H-2.405	36	1.750	82	3.228	66	2.598	46	1.811	4	0.157	50	1.969	70	8	123	13	3.0	6.6
H-2.1005	36	1.750	85	3.346	66	2.598	46	1.811	10	0.394	60	2.362	70	8	123	13	3.0	6.6
H-2.407	52	2.000	98	3.858	82	3.228	62	2.441	4	0.157	50	1.969	90	10	158	18	3.0	6.6
H-2.1007	52	2.000	102	4.016	82	3.228	62	2.441	10	0.394	60	2.362	90	10	158	18	3.0	6.6
H-2.408	68	2.625	116	4.567	100	3.937	80	3.150	4	0.157	50	1.969	113	13	198	22	3.0	6.6
H-2.1008	68	2.625	120	4.724	100	3.937	80	3.150	10	0.394	60	2.362	113	13	198	22	3.4	7.5
H-2.409	82	3.250	131	5.157	115	4.528	95	3.740	4	0.157	50	1.969	131	14	230	26	3.4	7.5
H-2.1009	82	3.250	135	5.315	115	4.528	95	3.740	10	0.394	60	2.362	131	14	230	26	4.0	8.8
H-2.410	100	3.875	148	5.827	130	5.118	112	4.409	4	0.157	50	1.969	137	15	239	27	4.5	9.9
H-2.1010	100	3.875	152	5.984	130	5.118	112	4.409	10	0.394	60	2.362	137	15	239	27	5.8	12.8
H-2.1011	125	4.875	185	7.283	160	6.299	138	5.433	10	0.394	60	2.362	205	23	360	40	6.8	15.0
H-2.1012	142	5.625	200	7.874	175	6.890	155	6.102	10	0.394	60	2.362	207	23	363	41	7.3	16.1
H-2.10125	156	6.125	215	8.465	190	7.480	170	6.693	10	0.394	60	2.362	226	25	396	45	8.5	18.7
H-2.1013	165	6.500	228	8.976	200	7.874	180	7.087	10	0.394	60	2.362	238	27	417	47	11.0	24.2
H-2.1014	186	7.375	250	9.843	222	8.740	202	7.953	10	0.394	60	2.362	266	30	466	52	12.0	26.4
H-2.1015	198	7.750	268	10.551	240	9.449	215	8.465	10	0.394	60	2.362	357	40	625	70	13.5	29.7
H-2.1015.5	218	8.500	288	11.339	260	10.236	235	9.252	10	0.394	60	2.362	389	43	680	76	14.0	30.8
H-2.1016.1	226	8.875	298	11.732	270	10.630	245	9.646	10	0.394	60	2.362	404	45	707	78	11.5	25.3
H-2.1017.0	242	9.500	313	12.323	285	11.220	260	10.236	10	0.394	60	2.362	428	48	749	84	14.0	30.8
H-2.1018.0	260	10.250	344	13.543	310	12.205	280	11.024	10	0.394	65	2.559	556	62	973	109	16.5	36.3
H-2.1019.0	280	11.000	364	14.331	330	12.992	300	11.811	10	0.394	65	2.559	594	67	1039	116	25.0	55.0
H-2.1019.5	305	12.000	392	15.433	355	13.976	325	12.795	10	0.394	70	2.756	640	71	1121	125	24.8	54.6
H-2.1020.0	308	12.125	406	15.984	366	14.409	330	12.992	10	0.394	70	2.756	787	88	1377	154	35.0	77.0
H-2.1021.0	336	13.250	448	17.638	400	15.748	360	14.173	10	0.157	70	2.756	955	107	1671	187	39.0	85.8
H-2.1022.0	366	13.250	460	18.110	422	16.614	390	15.354	10	0.394	70	2.756	816	91	1428	160	37.0	81.4
H-2.1023.0	396	15.625	486	19.134	450	17.717	420	16.535	10	0.157	70	2.756	820	92	1435	161	32.5	71.5

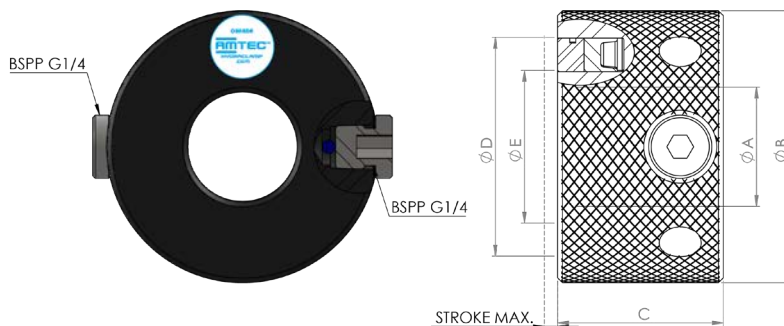



H-Type Nuts

SERIES H-3.4 & H-3.10

with AXIALLY LOCATED FLUID PORTS

Actuated by manual oil pump or hydraulic power unit. Self-aligning annular thrust ring with 4 or 10 mm maximum axial travel.

Model	Max Arbor Thread Size		Cannot Exceed Minimum Tool Ø		Verify diameters D & E contact an uninterrupted surface				Select Stroke as Required		Nut Width		Ensure Adequate Force Has Been Selected				Weight	
	Max Thread Ø		Nut Diameter		Thrust Ring Size				Thrust Ring Stroke		Nut Width		Clamping Force		Weight			
	A		B		D - OD		E - ID		S		C		400 BAR		700 BAR		KG	LBS
	mm	Inch	mm	Inch	mm	Inch	mm	Inch	mm	Inch	mm	Inch	kN	Tons	kN	Tons		
H-3.405	36	1.750	82	3.228	66	2.598	46	1.811	4	0.157	50	1.969	70	8	123	13	3.0	6.6
H-3.1005	36	1.750	85	3.346	66	2.598	46	1.811	10	0.394	60	2.362	70	8	123	13	3.0	6.6
H-3.407	52	2.000	98	3.858	82	3.228	62	2.441	4	0.157	50	1.969	90	10	158	18	3.0	6.6
H-3.1007	52	2.000	102	4.016	82	3.228	62	2.441	10	0.394	60	2.362	90	10	158	18	3.0	6.6
H-3.408	68	2.625	116	4.567	100	3.937	80	3.150	4	0.157	50	1.969	113	13	198	22	3.0	6.6
H-3.1008	68	2.625	120	4.724	100	3.937	80	3.150	10	0.394	60	2.362	113	13	198	22	3.4	7.5
H-3.409	82	3.250	131	5.157	115	4.528	95	3.740	4	0.157	50	1.969	131	14	230	26	3.4	7.5
H-3.1009	82	3.250	135	5.315	115	4.528	95	3.740	10	0.394	60	2.362	131	14	230	26	4.0	8.8
H-3.410	100	3.875	148	5.827	130	5.118	112	4.409	4	0.157	50	1.969	137	15	239	27	4.5	9.9
H-3.1010	100	3.875	152	5.984	130	5.118	112	4.409	10	0.394	60	2.362	137	15	239	27	5.8	12.8
H-3.1011	125	4.875	185	7.283	160	6.299	138	5.433	10	0.394	60	2.362	205	23	360	40	6.8	15.0
H-3.1012	142	5.625	200	7.874	175	6.890	155	6.102	10	0.394	60	2.362	207	23	363	41	7.3	16.1
H-3.10125	156	6.125	215	8.465	190	7.480	170	6.693	10	0.394	60	2.362	226	25	396	45	8.5	18.7
H-3.1013	165	6.500	228	8.976	200	7.874	180	7.087	10	0.394	60	2.362	238	27	417	47	11.0	24.2
H-3.1014	186	7.375	250	9.843	222	8.740	202	7.953	10	0.394	60	2.362	266	30	466	52	12.0	26.4
H-3.1015	198	7.750	268	10.551	240	9.449	215	8.465	10	0.394	60	2.362	357	40	625	70	13.5	29.7
H-3.1015.5	218	8.500	288	11.339	260	10.236	235	9.252	10	0.394	60	2.362	389	43	680	76	14.0	30.8
H-3.1016.1	226	8.875	298	11.732	270	10.630	245	9.646	10	0.394	60	2.362	404	45	707	78	11.5	25.3
H-3.1017.0	242	9.500	313	12.323	285	11.220	260	10.236	10	0.394	60	2.362	428	48	749	84	14.0	30.8
H-3.1018.0	260	10.250	344	13.543	310	12.205	280	11.024	10	0.394	65	2.559	556	62	973	109	16.5	36.3
H-3.1019.0	280	11.000	364	14.331	330	12.992	300	11.811	10	0.394	65	2.559	594	67	1039	116	25.0	55.0
H-3.1019.5	305	12.000	392	15.433	355	13.976	325	12.795	10	0.394	70	2.756	640	71	1121	125	24.8	54.6
H-3.1020.0	308	12.125	406	15.984	366	14.409	330	12.992	10	0.394	70	2.756	787	88	1377	154	35.0	77.0
H-3.1021.0	336	13.250	448	17.638	400	15.748	360	14.173	10	0.157	70	2.756	955	107	1671	187	39.0	85.8
H-3.1022.0	366	13.250	460	18.110	422	16.614	390	15.354	10	0.394	70	2.756	816	91	1428	160	37.0	81.4
H-3.1023.0	396	15.625	486	19.134	450	17.717	420	16.535	10	0.157	70	2.756	820	92	1435	161	32.5	71.5

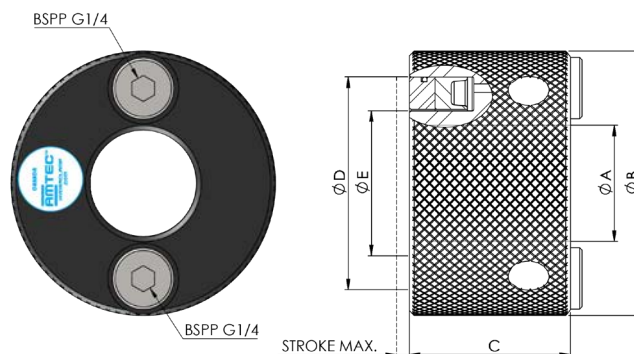



H-Type Nuts

Operating Instructions

Pressurize H-Type Nuts directly using hydraulic handpumps or hydraulic power units. Amtec Hydraclamp™ GX-Nipple and GX-Coupler high-pressure oil connections compliment H-Type Nuts.

A. Bleeding the Nut

1. Amtec H-Type Nuts are shipped either fully charged with hydraulic oil, or dry, depending on the design. Through transportation, handling or refilling, air may have been drawn into the pressure chamber of the nut. As with all hydraulic systems, air bubbles must be bled from the nut prior to operation to ensure reliable clamping forces.
2. Clean the threads and contact faces of the H-Type Nuts, arbors and/or mating tooling. Ensure all tooling is packed solidly together, ready for clamping.
3. Assemble the H-Type Nut into the intended tooling assembly and manually tighten against a continuous counter face (flat, full contact surface). Then back-off until one of the BSPP G 1/4 ports is in the 12 o'clock position for circular nuts, or "in-line" as the final nut in a series of square or rectangular nuts.
4. Remove the port plug connection on the H-Type Nut using the 6 mm hex wrench provided or, a suitable wrench to suit pipe connections.
5. First attach the required nipple to the open port and tighten firmly. Connect the coupler from the oil pump or power unit to the nipple, or connector, directly on the nut or on a header.
6. When you use Amtec GX-Coupler and GX-Nipples, see pages 78 (General GX-Coupler/Nipple page) and refer to online manual. If Amtec Hydraclamp™ handpump series 114.425... is also being used, rotate the 2-way control valve counter-clockwise until it stops in the "clamp" position. The handle will show two opposed pressure pads at the lower end.
7. Pump oil at minimum pressure into the H-Type Nut system until oil flows around the stud screw or open pipe connection, without air bubbles. Note: keep pressure to a minimum to ensure that the thrust ring is not pushed out.
8. Close the stud screw or pipe connector wrench tight, using the appropriate wrench, and remove the oil pumping connection if it is portable.
9. Hand tighten the H-Type circular nuts until the thrust ring touches the tooling counter face and check that the thrust ring is also flush with the end face of the nut body. For square or rectangular H-Type Nuts, adjust the tooling clamp faces so that they just touch the thrust ring and ensure that the thrust ring is flush with the end face of the nut body.
10. If the thrust ring is not flush with the nut body, open one connection and tighten circular nuts or, adjust the mating clamping faces for square or rectangular nuts, until the thrust ring is flush with the end face of the nut body. Oil has been expelled from the nut through the open port or connection and these connections must be retightened immediately to prevent future leakage.
11. The H-Type Nuts are now ready to pressurize.



B. Install Nuts and Apply Pressure

1. Clean the threads and contact faces of the Amtec H-Type Nuts, arbors and mating tooling. Ensure that all tooling or equipment is packed solidly together ready for clamping.
2. Assemble the H-Type Nuts onto the arbors or studs and tighten by hand against the mating tooling or equipment. Ensure that the thrust ring is flush with the face of the Amtec Nut.
3. If the thrust ring is not flush with the face of the Amtec Nut then follow step 10, Section A, on previous page.
4. Ensure that the thrust ring of the H-Type Nut is just lightly touching adjacent tooling or equipment to provide easy release of the nut later when clamping pressure is released.
5. Ensure that all oil connection faces are clean before pressurizing the H-Type Nuts.
6. Ensure that all oil connections are tight, using appropriate hand-held wrenches.
7. Activate the pumping system to obtain the appropriate clamping pressure, up to 700 bar (10,150psi).
8. If Amtec oil pumps are being used, see page 70.
9. The H-Type Nuts are now fully pressurized and ready for operation.

C. Release Pressure

1. Always ensure portable pumping connections are clean before connection to Amtec H-Type Nuts.
2. Once connections are firmly attached to the nuts or remote headers, pumps should be operated as per manufacturer's instructions to release oil pressure to sump.
3. If Amtec GX-Type Nipples and Couplers are being used, see page 78. If Amtec Oil Handpumps are also being used, see page 70 and page 71.
4. Since H-Type Nuts are single acting hydraulic systems, the thrust ring must be retracted to the home position, flush with the end face of the nut body after each use. Retraction can be done manually on circular nuts and by coil springs on square or rectangular nuts. To manually retract the thrust ring, oil must be dumped from the nut to the tank, through hoses or piping, as determined by the pump manufacturer's instructions. Once pressure has been released in the nut, it can be tightened to push the thrust ring home and the excess oil is sent to tank through the feed lines.

D. Remarks

1. DO NOT apply pressure to the H-Type Nuts when they are off-line. The thrust ring has no retainer and can be forced out of the pressure chamber causing distortion of the thrust ring and possible rupture of the seal.
2. Use only genuine Amtec Hydraclamp dual durometer (blue and black) seals and thrust rings to guarantee clamping reliability.
3. Use only ISO VG 22 or 32 hydraulic oil in the pump reservoir. Keep reservoir cap in place to eliminate dirt and dust contamination.

E. Service

1. For service and spare parts contact your distributor or Amtec Hydraclamp Inc. directly.



Rapid Shear Knife Change-Over Arrangements with H-049 Type Nuts



Oil activated, anti-rotational, Amtec H-Type Nuts, which we manufacture in either circular, rectangular or square to suit your design requirement.

Use Amtec H-Type Nuts to secure straight shear knives and holder/knife arrangements in strip, plate and bar product mills to facilitate rapid knife changes.

The bolster, shown below, is slotted to allow the bolt shanks to pass in or out of place while inserted through the knives and into the nuts as an assembly. Connect the assembly to your power unit or handpump using Amtec GX quick connect nipples and couplers or directly plumbed to your power unit.

The Amtec Rapid Shear Knife Change-Over system provides quick and easy removal of T-slotted shear blades. Simply applying hydraulic pressure clamps the shear blades into their respective holders with extreme force up to 10,000 PSI (700 bar).

Releasing hydraulic pressure rapidly unclamps the system to allow the operator to simply slide the knife out to be changed.

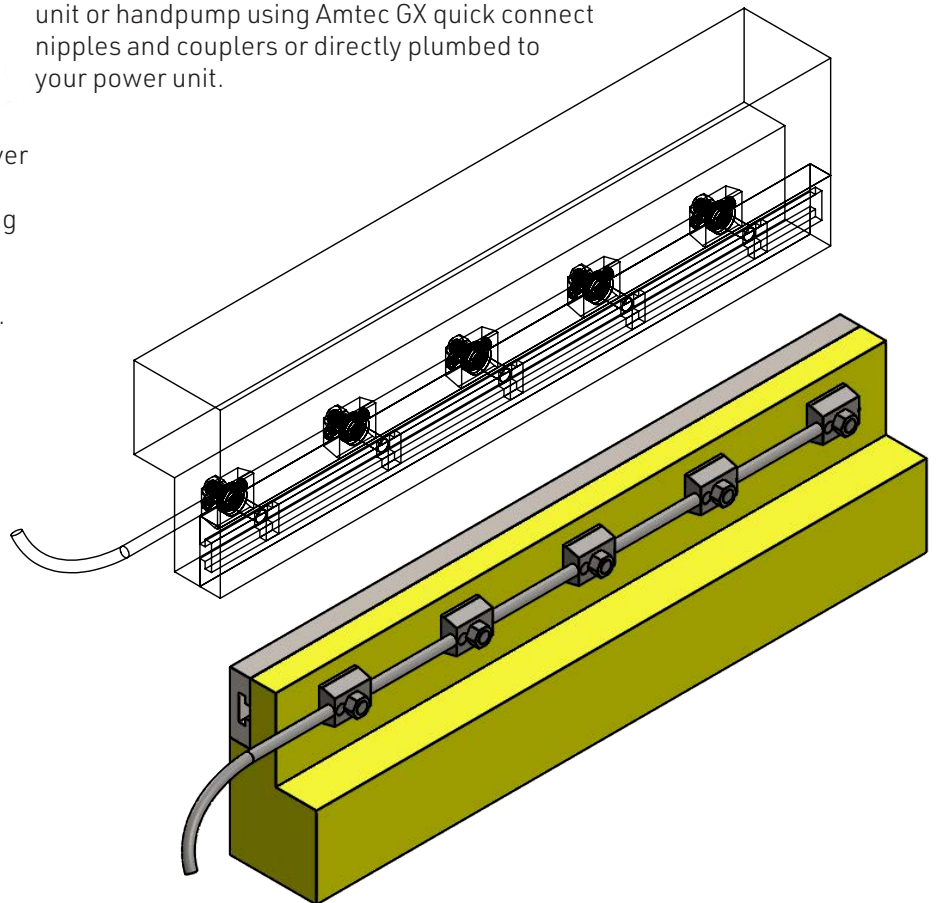

Amtec Hydraclamp Thread Builder Code

Amtec Hydraclamp offers all standard machine threads on the market. See page 7 for more details on threads. Amtec Hydraclamp requires the thread form, diameter, pitch and rotation direction at time of order. Below is the Amtec Hydraclamp how to order code for thread information.

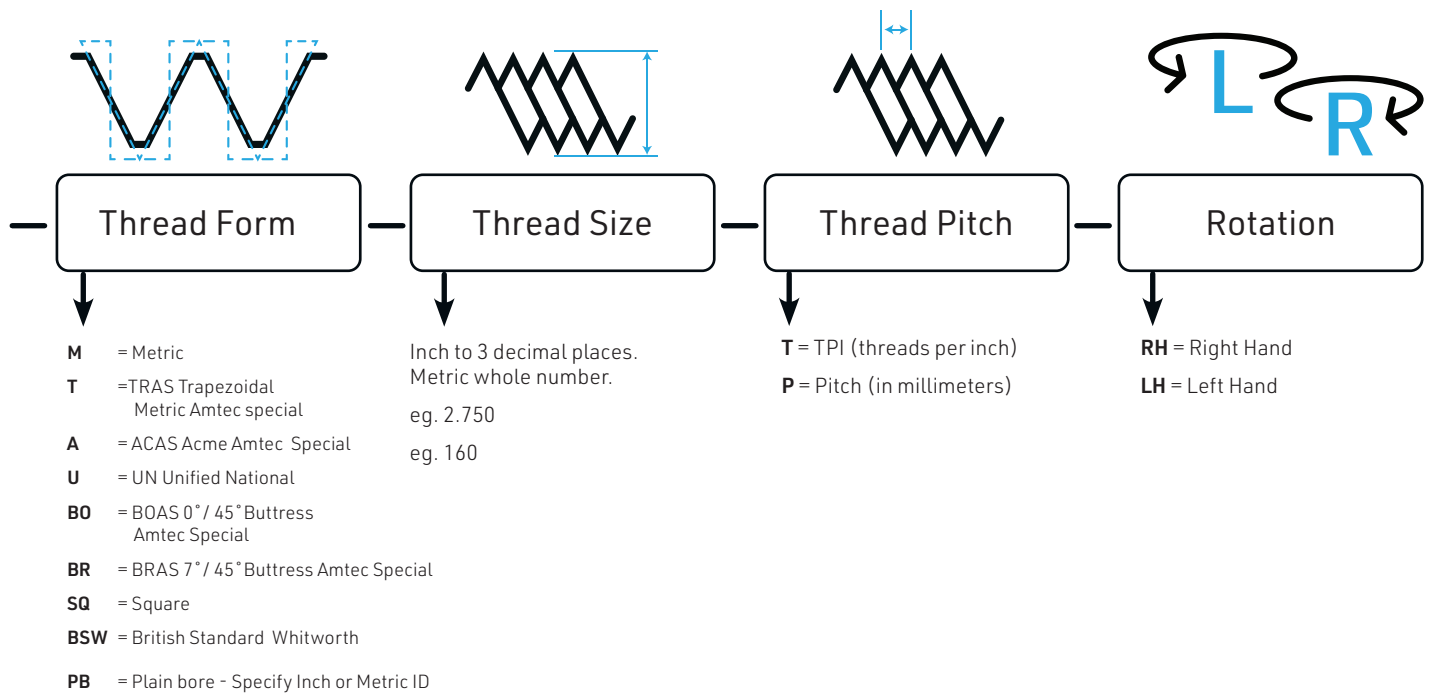

Examples:

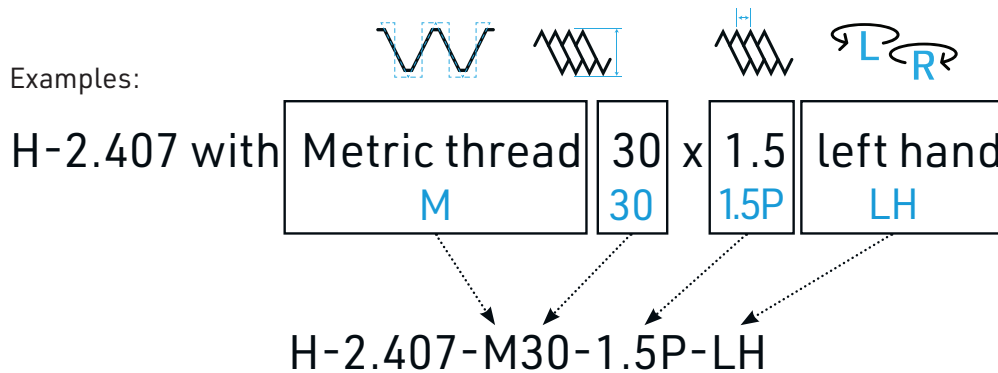

H-Type Nuts Accessories



Amtec Assist Bars

Part Number: 801.101.***.***

Install and remove nuts with ease.

See page 76 for details.

Hex Plugs

Fitting and Adapters for all H-Nuts.

See page 80 for details.



Replacement Parts

Replacement parts are available for all H-Nuts.

Contact Amtec or your local distributor for more information.



PO Check Valve

Pilot operated check valve maintains high pressure for extended periods.

See page 80 for details.

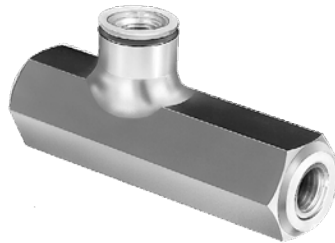

GX-Couplers & GX-Nipples

Rated for over 1000 bar (14,500 PSI)

Connects pumps or oil activated nuts, even under pressure.

See page 78 for details.



High-Pressure Handpumps

These reliable, high pressure pumps come in 250, 400 and 700 bar pressure ranges Operates H-nuts or GX-nuts. Custom options available.

See page 66 for details.



Step Nuts

SERIES 024 and 026
SINGLE and DOUBLE ACTING

Custom-designed, oil-activated, high clamp force, pre-tensioning devices.

Series 024 – Single Acting

The Amtec Hydraclamp Step Nut provides accurately controlled pre-tensioning service for tie-rods, shafts and arbors in rolling mills, pinion stands, hearing equipment and presses. Compact, highly efficient and single-acting, Amtec Step Nuts can be hard piped or plumbed through quick disconnect GX-Nipple and Coupler connections. For short periods of up to three weeks, internal pressures will be reliably constant. Pressure monitoring systems, such as our Series 550 Transponder (page 82) can be added where longer in-service periods are required.

The below cross-sectional drawing shows the left side in a depressurized state while the right side is in a pressurized state

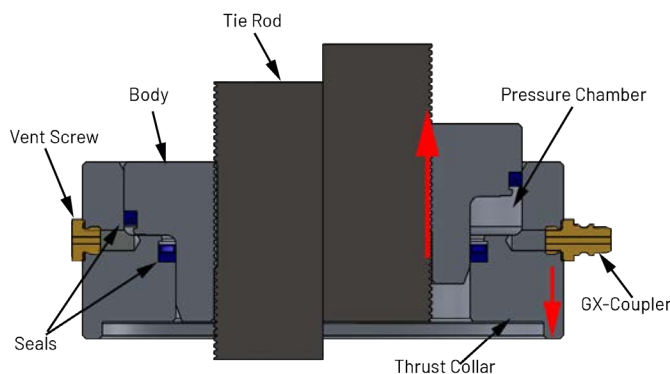

Series 026 – Double Acting

The double acting Amtec Hydraclamp Step Nut provides a custom-designed pressure chamber to exceed any pre-tensioning requirement, as well as a low pressure retraction chamber for easy reset. Amtec GX-Nipple and Coupler arrangement or hard piping connections with oil pumping systems can be designed to meet specific operating requirements for pressurizing, depressurizing and monitoring oil pressures. A dual acting oil pumping system is required to operate the Series 026 double acting Amtec Step Nut.

The below cross-sectional drawing shows the left side in a depressurized state while the right side is in a pressurized state. Pumping low pressure oil into the retraction chamber will return the thrust collar to the home position as shown on the left side of the drawing.

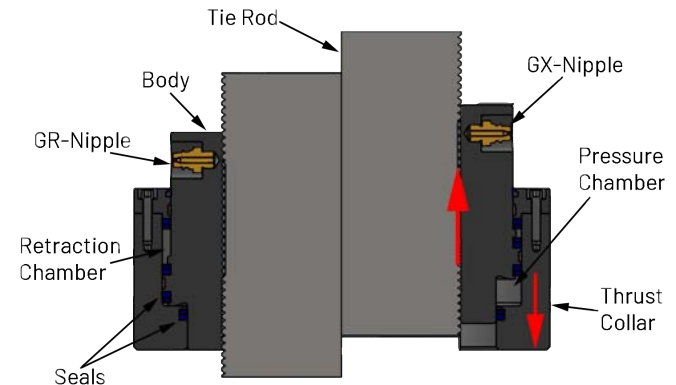

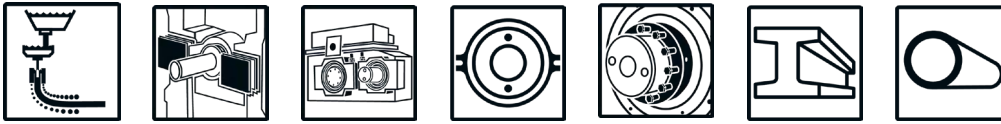

FEATURES:

- Standard black oxide finish for 120°C max. (250°F)
- Alloy tool steel body parts
- Stainless steel, electroless nickel or chromium plating for optional corrosion resistance
- Clean, efficient handpump operated or with hydraulic power unit





Block Nuts

SERIES 023

Hydraulic pre-tensioning with mechanical locking for long term clamping at precise tie rod elongation.

One of the principal advantages of the Amtec Block Nut is its availability for rapid release for adjustments or changes on equipment to which it is attached. A sudden product jam, a broken roll or knife, can be handled within minutes; pressurize, unscrew lock ring, release pressure, make required equipment repairs or changes, re-pressurize, tighten lock ring, release pressure, resume operation.

Amtec Block Nuts are custom engineered to meet specific pre-tensioning conditions for rolling mill frames, pinion stands, crop shear housings, plate and strip levelers, injection molding machines, and mechanical or hydraulic presses, to name just a few applications. Using a power unit or handpump, simply pump into the pressure chamber to cause separation between the body and the thrust collar. Since the body of the nut is threaded onto the tie rod, the tie rod stretches in response to the force created by input pressure. When a desired stretch is achieved, screw down the exterior, knurled lock ring tight against the thrust collar, blocking any future shrinkage of the tie rod for the entire period of operation, whether the operating period is for months or years.

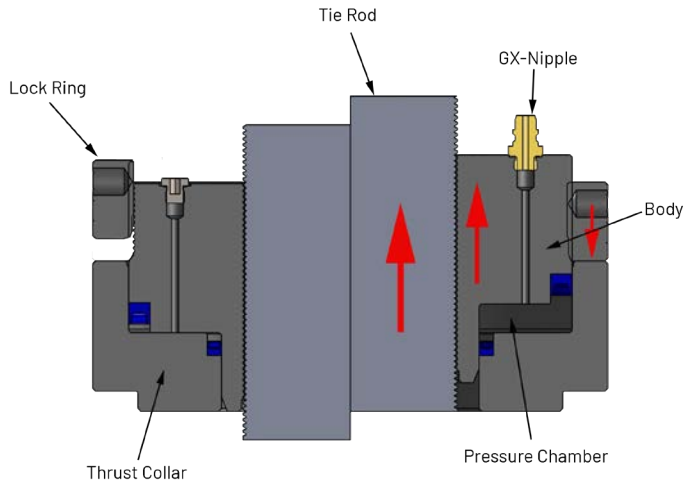

The Block Nut is a compact, self-contained device requiring only a remote oil pumping system, with a reservoir and pump, to activate or de-activate the pressure chamber at a predetermined pressure. Deactivation is accomplished by increasing the input pressure until the lock ring is freed up, allowing the ring to be unscrewed before pressure is released.

Oil pressure can be applied through Amtec GX-Nipple and GX-Coupler arrangements, for quick disconnect under pressure, or through hard piping from a remote header.

The above cross-sectional drawing shows the left side in a depressurized state while the right side is in a pressurized condition. The right side also shows the lock ring in the tightened position, against the thrust collar, to hold the tie rod in a pre-tensioned state.

To engineer an Amtec Block Nut we require complete dimensional drawings of tie rods, mill frames or housings, either exact clamping forces or separating forces, and type of hydraulic pumping system on-site or required to be supplied by Amtec.

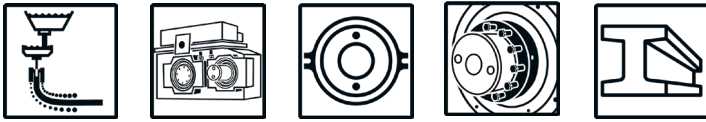

FEATURES:

- Standard black oxide finish for 120°C max. (250°F)
- Alloy tool steel body parts
- Stainless steel, electroless nickel or chromium plating for optional corrosion resistance
- Clean, efficient handpump operated or with hydraulic power unit

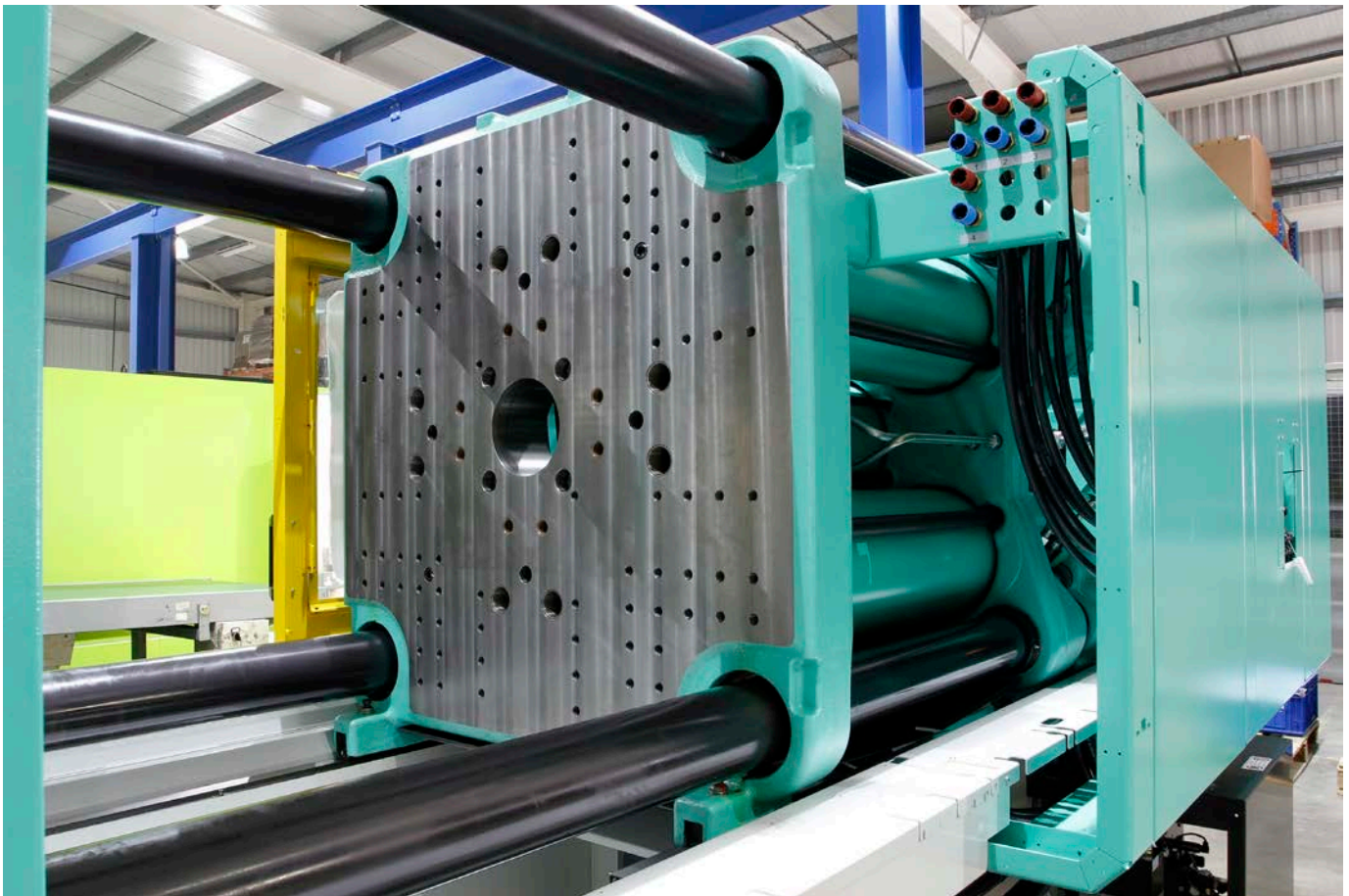



Greas-Bloc Nuts

SERIES F-410....

with MECHANICAL "BLOC-RING"

Actuated by manual or motorized pump for use with grease. Self-aligning thrust ring with 10mm maximum axial travel.

Fact:

- Up to 80% of clamping force can be lost to friction in tightening mechanical nuts and bolts. "Super Nuts" require tightening of "Jack Screws," which are subject to the same frictional loss, in addition to corrosion and distortion.

Feature:

- Amtec "Greas-Bloc" Nuts use grease pressure to apply axial clamping force without any loss of force through friction. Clamping force from 123 KN (27,650 lbs) and higher depending on size of nut required.
- Available stainless steel nut bodies resist corrosion during installation lifetime.
- Mechanical "Bloc-Ring" maintains initial clamping force throughout in-service term, regardless of time.

Selection:

- Specify bolt size and thread details
- Specify available flat counter face diameter around bolt
- Specify minimum clamping force required
- Confirm end face access to grease nipple is convenient
- Advise quantity required
- Custom designs to suit applications

Operation:

Amtec Greas-Bloc Nuts are the fastest way to tension tie rods, while avoiding thread damage altogether.

Simply spin the Greas-Bloc Nut onto the tie rod until it bottoms on the counter face and then pressurize the nut using your Amtec pump.

Once tension force is reached, tighten the bloc ring against the counter face and then release the pressure from the nut using the release screw. Your clamping force will remain until you once again pressurize the Greas-Bloc nut and back out the bloc ring. After once again depressurizing the nut, it easily spins off the tie rod.

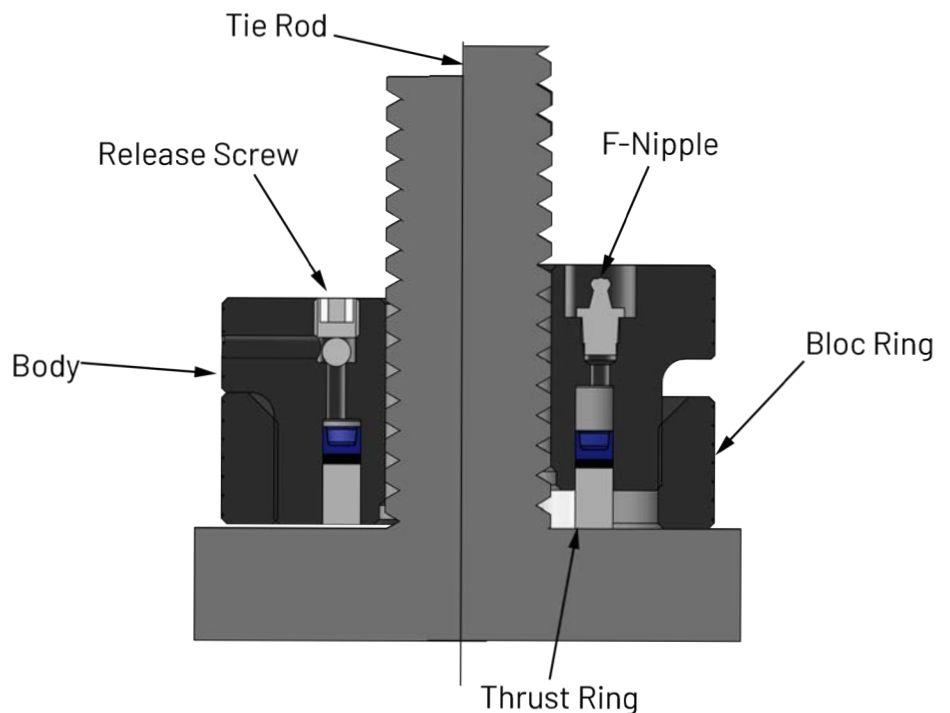

DOWNTIME IS NOT AN OPTION

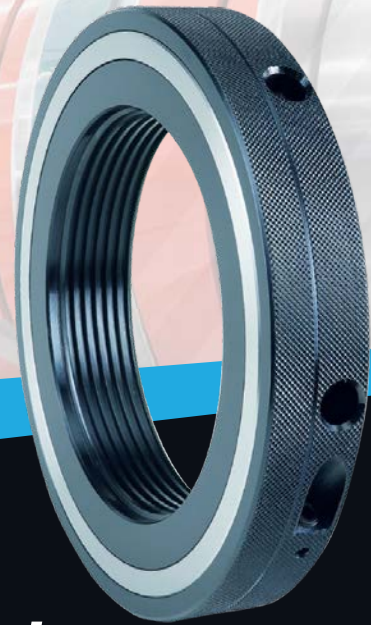

Hydraulic clamping nuts made with precision and capable of holding 10,000 PSI for weeks, keeping your machines running quality steel for longer.

Amtec Hydraclamp products are designed and engineered to help improve your productivity, quality, safety, and profitability.

THAT'S THE AMTEC ADVANTAGE.

MADE FOR: STEEL MILLS SLITTER WORK HOLDING SIDE TRIMMERS

TALK TO AN EXPERT

1-905-335-8233

amtechydraclamp.com

inquiries@amtechydraclamp.com



Clamp Rings

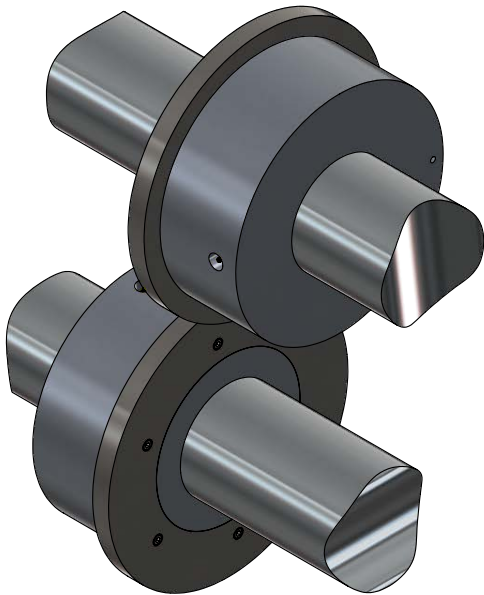

Hydraulic clamp rings use extreme internal pressure to clamp directly to plain arbors. Using our F-Nipples and handpump to bring the pressure chamber to over 10,000 PSI (700 bar) results in tons of friction force to keep knives, discs or spacers fixed firmly in place. No thread required!

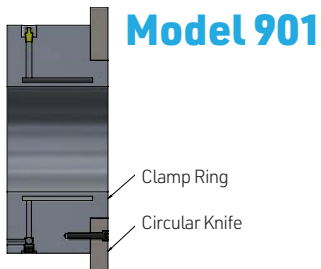

Circular knife is mounted on the seat and bolted against the shoulder. The hydraulic chamber extends under the knife seat.

An outboard stripper ring with steel core may be bolted against the face. This arrangement becomes Model 921.

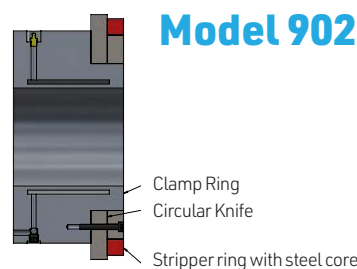

Circular knife and stripper ring with steel core are mounted on the same seat and bolted against the shoulder. The hydraulic chamber extends under the knife seat.

An outboard stripper ring with steel core may be bolted against the face. This arrangement becomes Model 922.

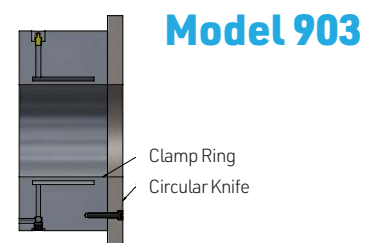

Circular knife I.D. equals the clamp ring I.D. The knife is bolted against the face of the clamp ring.

An outboard stripper ring with steel core may be bolted against the face. This arrangement becomes Model 923.

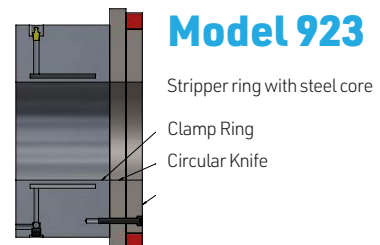
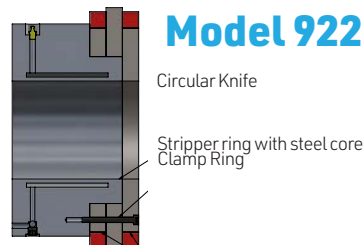
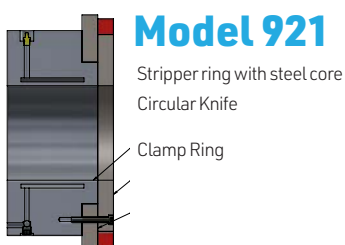



Amtec Hydraclamp Clamp Rings are precision engineered and manufactured to the tightest tolerances. When selecting and using clamp rings, it is imperative you understand your arbor(s) must also be precision engineered using the highest quality, hardened steel to ensure the clamp ring has a perfect surface to grasp. Any burs, dents or deformation will prevent either complete installation or effective clamping.

Because clamp rings are pressure welded prior to precision grinding, some deformation of the ID may be possible after pressure cycles, even in spite of annealing and normalization. Some cases may require Amtec Hydraclamp to regrind the ID to remove any elliptical deformation.

Please contact your local distributor or Amtec Hydraclamp directly for the available configurations and sizes of Clamp Rings.

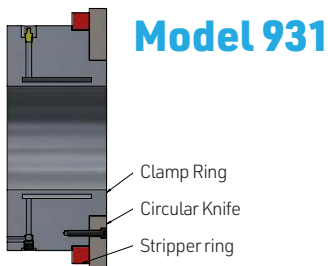

An inboard stripper ring and circular knife are mounted on separate seats with the knife bolted to the shoulder. The hydraulic chamber extends under the knife seat.

An outboard stripper ring with steel core may be bolted against the face. This arrangement becomes Model 941.

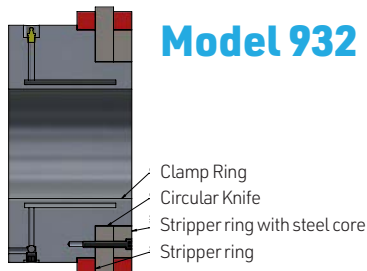

Circular knife and stripper ring with steel core are mounted on the same seat and bolted against the shoulder to retain an inboard, coreless stripper ring on a separate seat. The hydraulic chamber extends under the knife seat.

Circular knife and two stripper rings with steel cores are mounted on the same seat and bolted against the shoulder. This arrangement becomes Model 942.

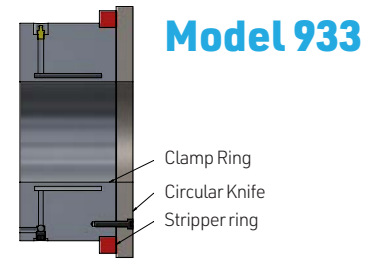

Circular knife I.D. equals the clamp ring I.D. The knife is bolted against the face of the clamp ring. Retains inboard, coreless stripper ring

An outboard stripper ring with steel core may be bolted against the face. This arrangement becomes Model 943.

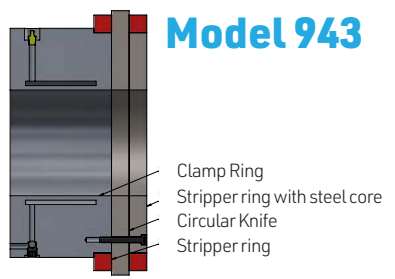
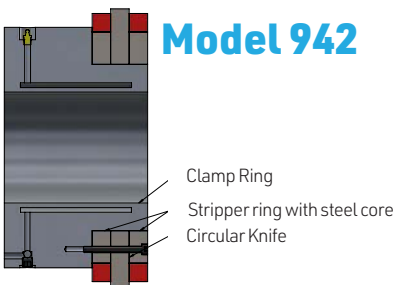
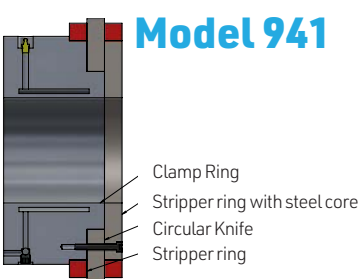



Handpumps

CHAIN Series 112.100.200...

A portable, grease cartridge type handpump with chain-type retraction handle for pressurizing all Amtec Hydraclamp F-Type clamping devices up to 700 bar (10,150 psi) maximum.

Available Models	Maximum Operating Pressure
112.100.200-250	250 bar (3,625 psi)
112.100.200-400	400 bar (5,800 psi)
112.100.200-700	700 bar (10,150 psi)

All components are rated at 850 bar (12,325 psi).

The custom engineered Amtec 112.100.200 handpump exceeds high pressure requirements for all types of hydraulic clamping devices using Amtec F-Nipples or standard fittings. Not to be confused with simple grease guns, many years of field engineering has resulted in a safe, convenient and durable handpump to meet all specifications.

Our internal relief valve provides variable, specific clamping control. Once the preset pressure is reached, excess grease is dumped back into the grease chamber without any increase in pressure to the clamping device. The pressure release thumb screw dumps pressure from the F-Coupler and extension back into the grease chamber. This allows for easy removal of the F-Coupler from the F-Nipple and prevents damaging the coupler, the nipple or straining the operator. Also, all bypass grease is retained inside the pump to reduce contamination of equipment. The pump's swivel pressure gauge offers visual confirmation of pressure level from any angle.

Use standard 400 ml grease cartridges with manually inserted red plastic follower. The chain type retraction handle requires less force to compress the follower coil spring and ensures positive expulsion of all grease in the cartridge. Our flexible and rigid extensions are provided with every new pump. Flexible is 600 mm (23.62") long and rigid is 160 mm (6.30"). Both extensions carry 4-jaw F-Couplers. The long handle is provided for ease of pumping to maximum pressure. All new Amtec handpumps come with the following spare items:

1. Three grease cartridges (one installed in pump)
2. Two spare red plastic follower seals
3. Flexible extension with F-Coupler (rigid coupler comes installed)

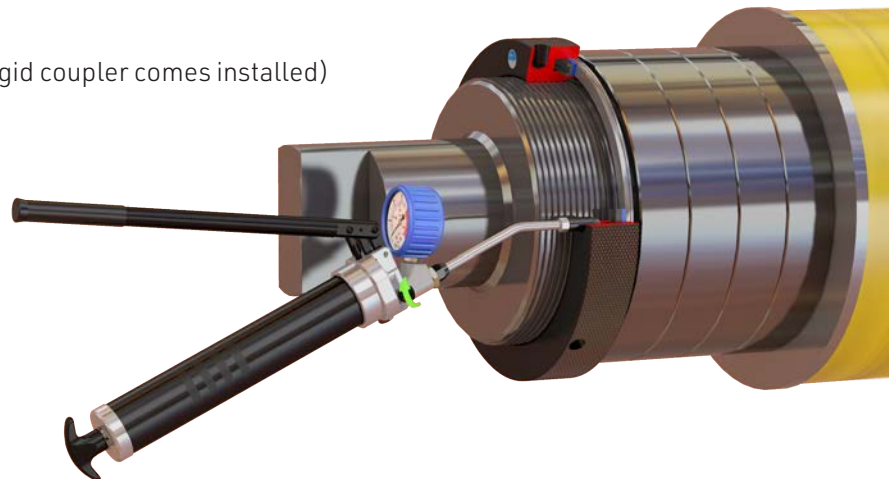

112.100.200-XXX Rod Type Handpump Parts Breakdown

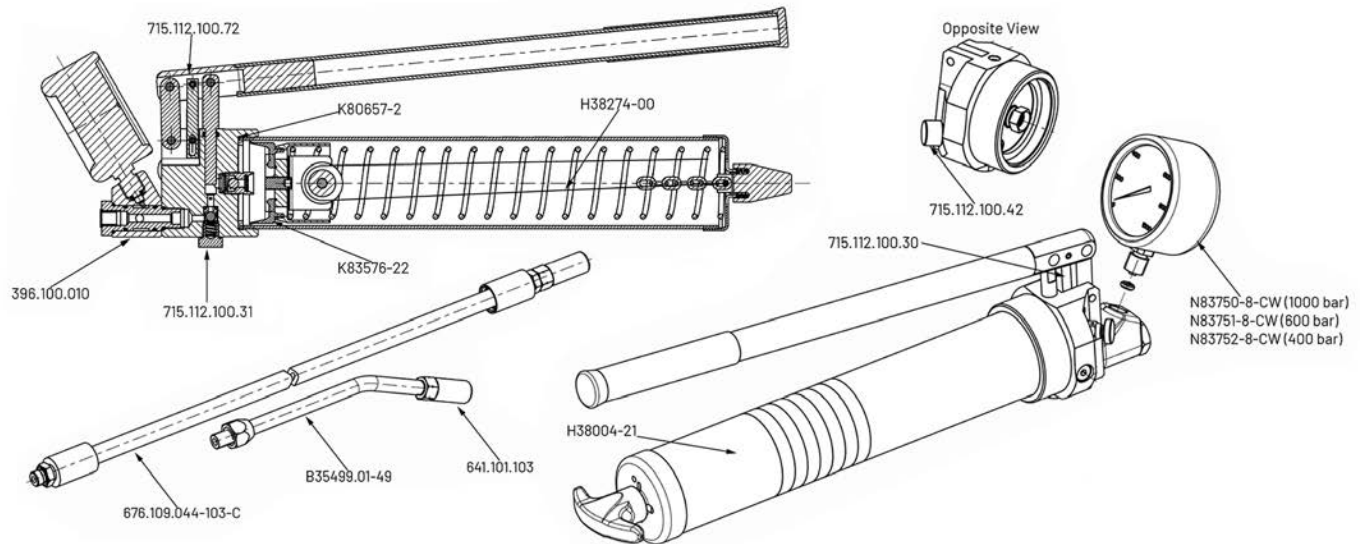

Amtec Hydraclamp chain-type handpumps are high quality, precision made items with legendary reliability. Because of their high-quality nature and repeated serviceability, your pump enjoys a nearly infinite service life. If you're not comfortable servicing your own pump, please send it to your local distributor or Amtec Hydraclamp directly, where it will be returned to operating condition. The list below shows only common replacement parts, but all parts are available upon request.

112.100.200 - Common Replacement Parts

Part Number	Description	
K83576-22	Red Plastic Follower Seal	Most Common Items
N83750-8-CW	1000 Bar Pressure Gauge with Protective Cover (for 700 bar pumps)	
N83751-8-CW	600 Bar Pressure Gauge with Protective Cover (for 400 bar pumps)	
N83752-8-CW	400 Bar Pressure Gauge with Protective Cover (for 250 bar pumps)	
641.101.103	F-Coupler	
801.200.002	400ml Preplacement Grease Cartridge (not pictured)	
715.112.100.72	Handle Assembly Kit	
396.100.010	Swivel	
715.112.100.31	Non-Return Valve (Check Valve) Kit	
K80657-2	Body Seal	
H38195-05	Rod Kit Internals	
715.112.100.30	Head & Handle Kit	
H38004-21w	Barrel	
676.109.044-103-C	Flexible Extension with F-Coupler	
B35499.01-49	Rigid Extension with F-Coupler	
715.112.100.42	Black Pressure Release Thumb Screw	



Handpumps

ROD Series 112.110.210...

A portable, grease cartridge type handpump with rod-type retraction handle for pressurizing all Amtec Hydraclamp F-Type clamping devices up to 700 bar (10,150 psi) maximum.

Available Models	Maximum Operating Pressure
112.110.210-250	250 bar (3,625 psi)
112.110.210-400	400 bar (5800 PSI)
112.110.210-700	700 bar (10,150 psi)

All components are rated at 850 bar (12,325 psi).

The custom engineered Amtec 112.110.210 handpump exceeds high pressure requirements for all types of hydraulic clamping devices using Amtec F-Nipples or standard fittings. Not to be confused with simple grease guns, many years of field engineering has resulted in a safe, convenient and durable handpump to meet all specifications. Our internal relief valve provides variable, specific clamping control. Once the pre-set pressure is reached, excess grease is dumped back into the grease chamber without any increase in pressure to the clamping device. The pressure release thumb screw dumps pressure from the F-Coupler and extension back into the grease chamber. This allows for easy removal of the F-Coupler from the F-Nipple and prevents damaging the coupler, the nipple or straining the operator. Also, all bypass grease is retained inside the pump to reduce contamination of equipment. The pump's swivel pressure gauge offers visual confirmation of pressure level from any angle.

All components are rated at 850 bar (12,325 psi). Use standard 400 ml grease cartridges with manually inserted red plastic follower. However, the rod-type handpump is also easily refilled using our Bulk Fill System (page 69). The rod type retraction handle requires less force to compress the follower coil spring and ensures positive expulsion of all grease in the cartridge. Our flexible and rigid extensions are provided with every new pump. Flexible is 600 mm (23.62") long and rigid is 160 mm (6.30"). Both extensions carry 4-jaw F-Couplers. The long handle is provided for ease of pumping to maximum pressure. All new Amtec handpumps come with the following service items:

1. Three grease cartridges (one installed in pump)
2. Flexible extension with F-Coupler (rigid coupler comes installed)



112.110.210-XXX Rod Type Handpump Parts Breakdown

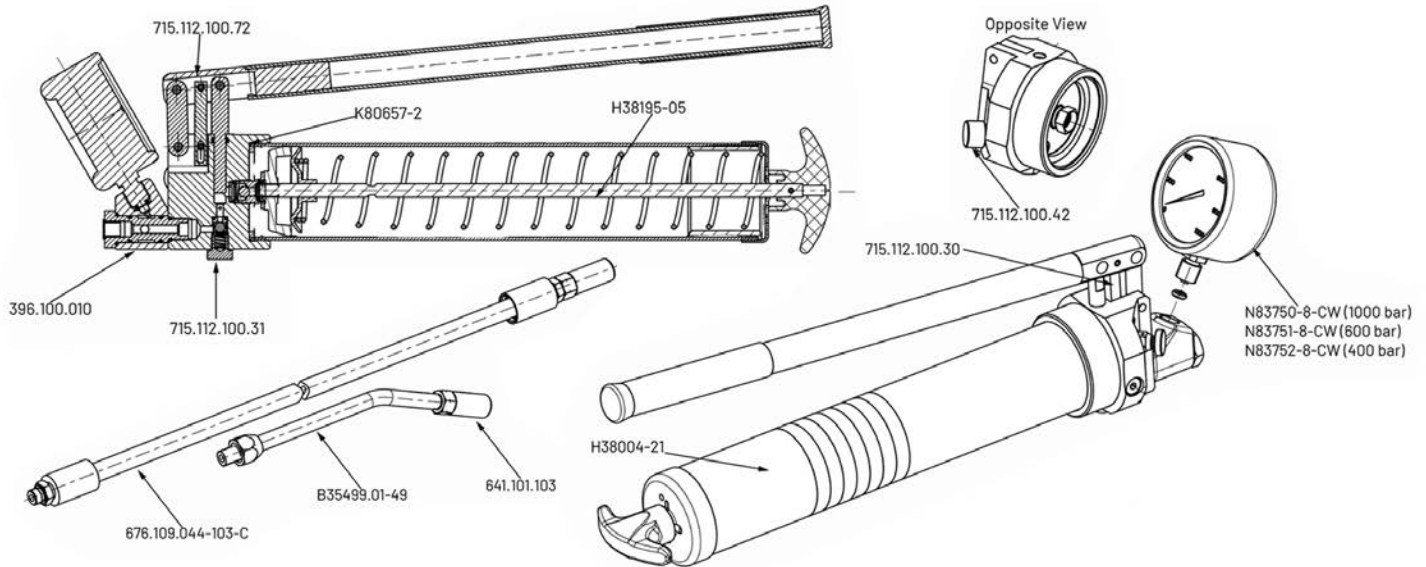

Amtec Hydraclamp rod type handpumps are high quality, precision made items with legendary reliability. Because of their high-quality nature and repeated serviceability, your pump enjoys a nearly infinite service life. If you're not comfortable servicing your own pump, please send it to your local distributor or Amtec Hydraclamp directly, where it will be returned to operating condition. The list below shows only common replacement parts, but all parts are available upon request.

112.110.210 - Common Replacement Parts

Part Number	Description
N83750-8-CW	1000 Bar Pressure Gauge with Protective Cover (for 700 bar pumps)
N83751-8-CW	600 Bar Pressure Gauge with Protective Cover (for 400 bar pumps)
N83752-8-CW	400 Bar Pressure Gauge with Protective Cover (for 250 bar pumps)
641.101.103	F-Coupler
801.200.002	400ml Preplacement Grease Cartridge (not pictured)
715.112.100.72	Handle Assembly Kit
396.100.010	Swivel
715.112.100.31	Non-Return Valve (Check Valve)Kit
K80657-2	Body Seal
H38195-05	Rod Kit Internals
715.112.100.30	Head & Handle Kit
H38004-21	Barrel
676.109.044-103-C	Flexible Extension with F-Coupler
B35499.01-49	Rigid Extension with F-Coupler
715.112.100.42	Black Pressure Release Thumb Screw

Most Common Items



Oil Handpumps

SERIES 114.427...

A portable, or permanently mounted handpump for pressurizing all Amtec oil activated clamping devices up to 700 bar (10,150 psi).

Standard Models	Maximum Operating Pressure	Reservoir Capacity	Weight
114.427.256-400	400 bar (5800 PSI)	1.8 L (0.47 gal)	7.8kg (17.2lbs)
114.427.406-400	400 bar (5800 PSI)	4.0 L (1.05 gal)	11kg (24.2lbs)
114.427.259-700	700 bar (10,150 PSI)	1.8 L (0.47 gal)	7.8kg (17.2lbs)
114.427.409-700	700 bar (10,150 PSI)	4.0 L (1.05 gal)	11kg (24.2lbs)

We custom engineer Amtec Series 114.427 oil handpumps to handle high pressure requirements for many types of oil activated clamping devices. Decades of field engineering have resulted in a safe, convenient and durable handpump to meet most specifications.

A 2-way control valve is provided to activate the clamping position and then dumping fluid back to the reservoir to provide operational simplicity. A visually coded/mechanically interlocked Amtec GX-Coupler, included with every pump, offers positive lock to our GX-Nipple. The quick-disconnect function for clamping devices ensures safe and convenient interaction between the pump and the clamping device under all operating conditions. Operating pressure can be pre-set to ensure specific clamping control. Once the preset pressure is reached, excess oil is dumped back into the reservoir through the internal relief valve, without any increase in pressure to the clamping device. Amtec presets the pressure control, which is located inside the reservoir to prevent unwarranted changes.

Amtec recommends standard ISO AW 32 or 46 hydraulic oil. Flexible hose extensions may be added, as required for long distance operation. The 114.427 compact size and light weight provide convenience and ease of movement for use in restricted areas. The pump is portable, or it can be permanently mounted either horizontally or vertically. Models available for various pressure and capacity requirements. We also offer 4-way directional valves for double-acting clamps, such as our Step Nuts (page 58).

Additional Features:

1. Steel pump body, handle, linkage, fittings and reservoir
2. Steel valve seats
3. Rubber covered pressure gauge
4. Many pumps have been in continuous service for over 20 years



See website for operating manuals.



Mobile Grease Pumping System

SERIES 114.427...

A permanently mounted, portable, air-powered pump for pressurizing all Amtec grease activated clamping devices up to 517 bar (7500 PSI).

A. Common Features

- 2-wheeled wide-base dolly with 8" diameter wheels for superior stability
- 50:1 ratio pump with inductor plate and bleed valve
- Manual elevator support to raise pump out of the pail for convenient changing of grease supply
- Fits standard 17 kg (37 lb) pail of grease
- Preset air regulator for 80 PSI, but operational up to 150 PSI
- Pistol grip dispensing valve
- 3-way Z-swivel for convenient access to clamping device at any angle
- Amtec rubber protected pressure gauge for visual control of activating pressure
- Pressure release valve, rigid extension, and our famous 4-jaw F-Coupler
- 3 meter (10 ft) long reinforced flexible hose with 20,000 psi rating

B. Optional Features

- Pumping pressures from 250 to 517 bar (3,625 PSI to 7500 PSI)
- Custom hose lengths available to suit requirements
- Stationary support base (without 2-wheeled dolly) for larger volume grease barrels
- Kits available for 55kg and 180kg drums

C. Benefits

- Eliminate cartridge changing or frequent bulk filling of handpumps
- Larger available grease volume for cost effective grease dispensing
- Less risk of dirt contamination during grease supply changeover
- Reduced physical strain to reach operating grease pressure
- Uniform, preset, pressure control
- Spare parts readily available
- Single-handed operation

D. Grease Recommendation

- Petro Canada Peerless OG-1
- Shell Alvania EP1; Esso/Exxon Unirex EP1
- Mobil Mobilith AW1 or equivalent grease with rating NLGI-1/EP-1, penetration 325 at 25°C



Bulk Fill Pumping System

MODEL 193.112.110.011



The Amtec Hydraclamp bulk fill system takes the pain and mess away from using individual grease cartridges. When combined with our 112.110.210 Series Rod Type Handpump (see page 68), the system provides months worth of grease supply while never having to open up the handpump.

Simply connect the filler cap to the bulk fill pumping system's filler assembly and pump the handle, providing a clean, quick method of refilling Amtec Rod Type handpumps until the grease pail is empty.

The Bulk Fill Pumping System is available for many bucket or drum standards. Get in touch with Amtec Hydraclamp or one of our distributors for more information.

See website for operating manuals.



BLOCK RING

Special Options

Amtec Hydraclamp is happy to accommodate special options whenever required. In fact, over the decades, Amtec has created dozens of special features for unique engineering requirements.

The options listed here represent a portion of our capabilities, so if you require a feature for your own project and you don't see it here, reach out to us and provide your details.

Partial List of Special Options

- Block Rings - these rings are threaded to the OD of a nut to provide a permanent method of locking after completion of pre-tensioning using one of our standard nuts or clamps.
- Longer or shorter stroke thrust rings
- Thinner nut body (note: this may reduce maximum pressure rating)
- Radial nipple access (our F-8, K-6, GX-4 and H-2 nuts are manufactured with tangential nipples with OD access)
- Steel assist bar drill bushings for aluminum nuts to extend the life of the assist bar holes
- Stainless steel nut bodies or thrust rings
- Blind Nut (thread does not break through the back of the nut)
- End face assist bar holes. Spanner wrench holes are also available
- Extra wide thrust ring or dual thrust rings
- Threaded nut outside diameter
- Zinc, nickel or other surface treatment
- Threaded male studs
- Bayonet ring locking interface
- Tapped and threaded holes as required
- Counter-bored nut ID or partial thread depth
- Counter-bored or turned down thrust ring
- Chamfered or tapered nut OD



BAYONET RING



BLIND NUT



THREADED MALE STUD

Accessories

F-Nipple

Part # 710.101.005

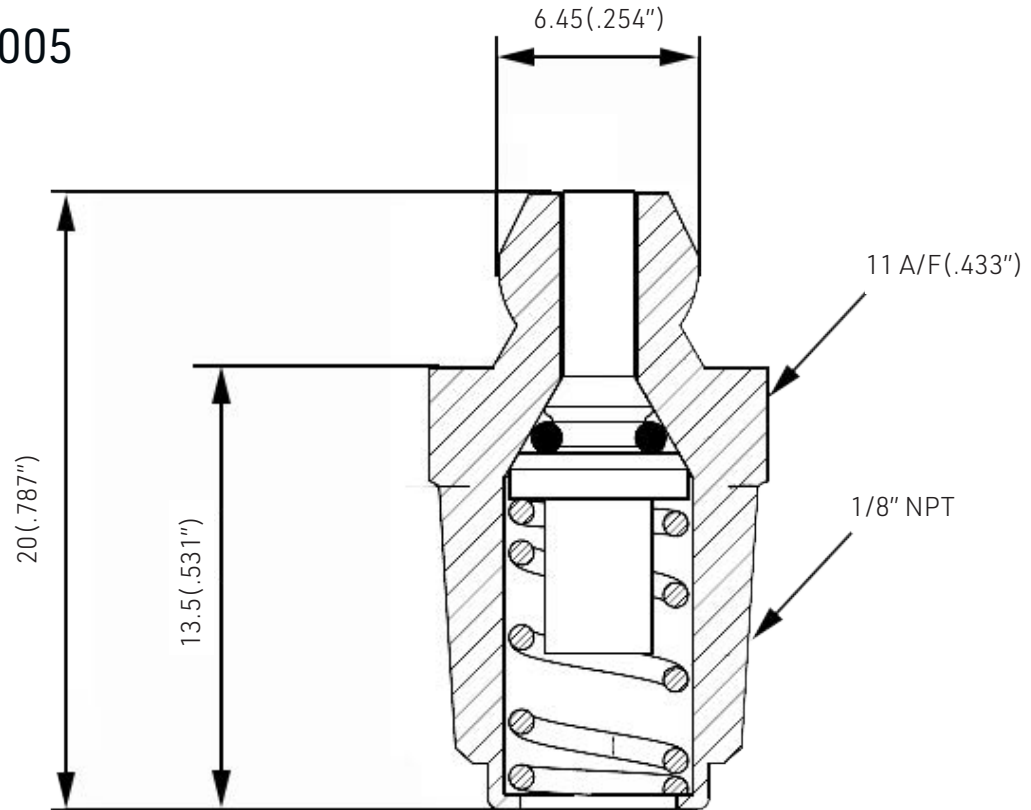

Specially engineered one-way valve, high-pressure, heavy-duty, grease transfer fitting for use in all Amtec F-Type Hydraulic Nuts and other special lubrication applications.

- Hardened steel body
- Internal pin to prevent entry of dirt during operation
- High-strength internal sealing system for long life
- Tip dimensions compatible with many standard, low pressure fittings, allowing the use of low and high pressure grease input connectors as required.
- Always release input pressure at the handpump before attempting to remove the handpump coupler (connector) from the F-Nipple.
- Operating pressure 300 to 700 bar (4350 to 10,150 psi)
- Weight 0.08 Kg (0.18 lbs)

Note: Before installing new F-Nipples, always apply (2) wraps of Teflon tape over the thread, or apply liquid thread sealant, and tighten using 11 mm or 7/16" socket wrench.

Accessories

F-Coupler

Part # 641.101.103

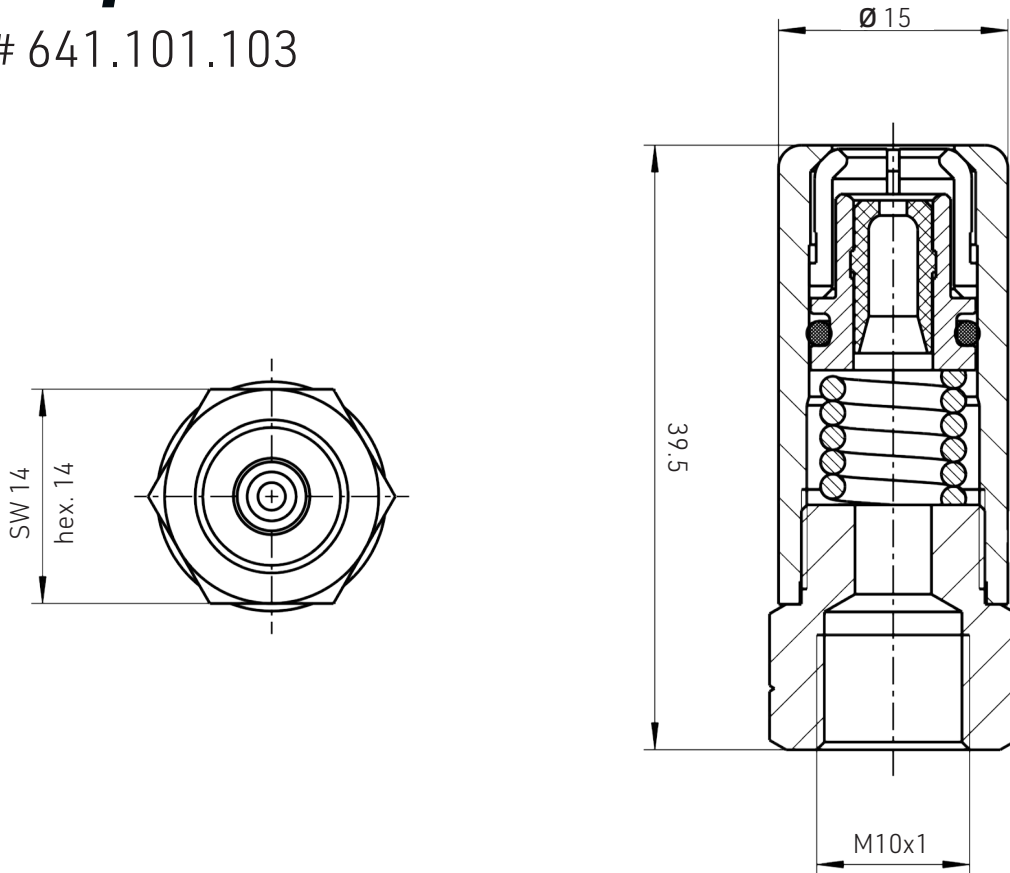

Special Four-Jaw Coupler; heavy-duty, high-pressure version, for reliable, efficient grease transfer from the Amtec Handpumps to the Amtec F-Nipple mounted in the Amtec F-Type Hydraulic Nuts.

- Allows for easy coupling and uncoupling on standard dimensioned grease fittings
- Absolute grip ensured at angles up to 12 degrees
- 4-jaw grip ensures minimal grease leakage around the F-Nipple
- To disconnect; release input pressure from the Amtec Handpump by opening the black thumb screw, tilt the handpump lightly and rotate while extracting from the Amtec F-Nipple.
- This above procedure ensures a long service life for the F-Coupler and the F-Nipple.
- Maximum operating pressure: 700 bar (10,150 psi)
- External Diameter: 15 mm (0.591")
- Width Across Flats: 14 mm (0.551")
- Length: 40 mm (1.575")
- Internal Thread: M10 x 1.0 p
- Weight: 0.04 Kg (0.09 lbs)

Note: Before installing new F-Couplers, always apply (2) wraps of plumbers Teflon tape over the external thread, or apply liquid thread sealant, and tighten using 14 mm or 9/16" open end wrench.

Accessories

Assist Bars



Assist Bar	Used For Amtec Nuts
801.101.125.065	K-7.101L to K-7.202L
801.101.128.095	K-6.104 to K-6.206L K-7.103L to K-7.206L
801.101.200.127	F-8.405 to F-8.1011 F-9.405 to F-9.1011 K-6.107L to K-6.211L K-7.107L to K-7.410L H-2.405 to H-2.1011 H-3.405 to H-3.1011
801.101.280.127	F-8.412 to F-8.1015 F-9.412 to F-9.1015 K-6.212L to K-6.215L H-2.412 to H-2.1015 H-3.412 to H-3.1015
801.101.203.190	F-8.415.5 to F-8.1016.1 F-8.411.017 to F-8.1015.517 F-9.415.5 to F-9.1016.1 F-9.411.017 to F-9.1015.517 K-6.216L to K-6.217L H-2.415.5 to H-2.1016.1 H-3.415.5 to H-3.1016.1

Assist Bar	Used For Amtec Nuts
801.101.305.190	F-8.417.0 to F-8.1019.5 F-9.417.0 to F-9.1019.5 F-8.417.017 to F-8.1019.517 F-9.417.017 to F-8.1019.517 H-2.417.0 to H-2.1019.5 H-3.417.0 to H-3.1019.5 GX-4.415.5 to GX-4.1018 GX-5.415.5 to GX-5.1018
801.101.360.190B	F-8.1020.0 to F-8.1023.0 F-8.420.017 to F-8.1020.107 F-9.1020.0 to F-9.1023.0 F-9.420.017 to F-9.1023.017 H-2.1020.0 to H-2.1023.0 H-3.1020.0 to H-3.1023.0 GX-4.1019 to GX-4.1025 GX-5.1019 to GX-5.1025

Use assist bars to retract the thrust ring into the nut body after production and before removing the clamp.

The assist bar also helps remove nuts on sticky arbors while preventing hammering or other costly damage to clamps.

See nut operating instructions for more information on using Amtec assist bars.



Accessories

Grease Recommendations

for all AMTEC Pumping Systems

General specifications for cartridge, pail or barrel

A) For North America, Europe and Asia

Note: Summer conditions/heated facilities use EP-2 (Calcium Sulphonate)

Winter conditions/unheated facilities use EP-1 (Calcium Sulphonate)

- Petro Canada Peerless OG-1/2;
- Shell Alvania EP-1/2;
- Esso/Exxon Unirex EP-1/2;
- Mobil Mobilith AW1/2;
- Or equivalent NLGI-1/EP-1 grease, penetration 325 at 25°C
- Or equivalent NLGI-1/EP-2 grease, penetration 270 at 25°C

B) For Tropical Climates

- Petro Canada Peerless OG-2;
- Shell Alvania EP-2;
- Esso/Exxon Unirex EP-2;
- Mobil Mobilith AW2;
- Or equivalent NLGI-2/EP-2 grease, penetration 270 at 25°C

C) For Sub-Zero Climates

- Petro Canada Peerless OG-0;
- Shell Alvania EP-0;
- Esso/Exxon Unirex EP-0;
- Mobil Mobilith AW0;
- Or equivalent NLGI-0/EP-0 grease, penetration 365 at 25°C



Accessories

GX Coupler & GX Nipples

MODELS 641.205.010 / 710.205.010
700 BAR WORKING PRESSURE

Quick disconnect, zinc plated, high-pressure oil connector for use with GX-Nipples exclusively.

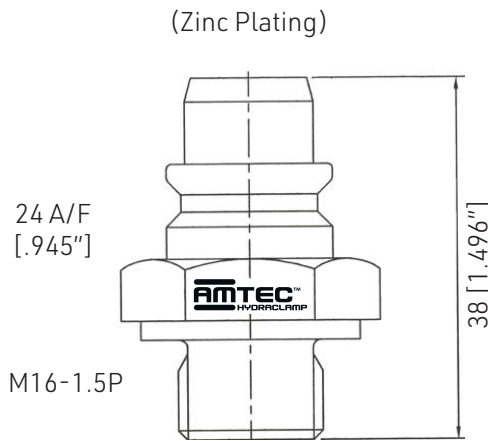

GX-Nipple – 710.205.010

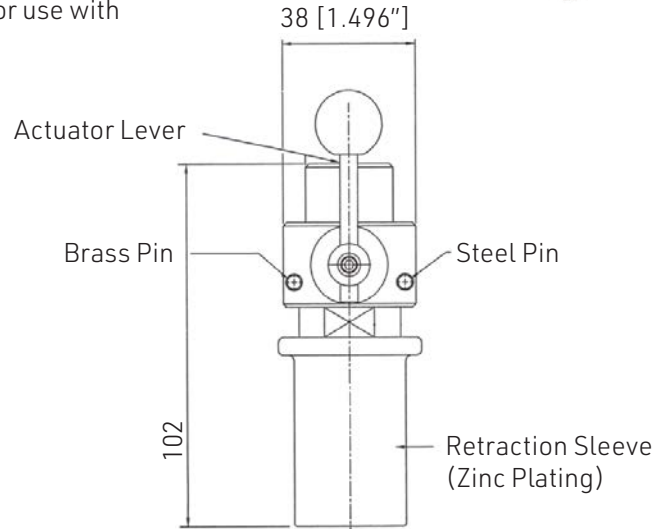

GX-Coupler – 641.205.010

General:

This unique, compact, Amtec designed and built, high-pressure oil connector and nipple arrangement allows for rapid connection and release with full pressure maintained in the associated clamping device.

Safety:

1. Zinc Plating identifies mating GX-Coupler and GX-Nipple by sight.
2. Mechanical interlocks allow only GX components to fully connect before pressurizing.
3. Pressures up to 1,000 bar (14,500 psi) can be handled under special conditions.
4. Compact design allows the GX-Nipple to be fully recessed into the clamping device to prevent operating damage, while the GX-Coupler is easily operated with one hand.
5. Other visually coded, interlocked models are available for low pressure and/or special service.

Convenience:

1. Positioning of the actuator lever and pulling back on the retraction sleeve allows for rapid connection or separation of the GX-Coupler and the GX-Nipple.
2. Pressurized oil is directed to the clamping device or to the reservoir by placing the actuator lever against the brass pin or the steel pin respectively.
3. A ball-type locking arrangement allows for a smooth, positive interlock between the GX-Coupler and the GX-Nipple.

Durability:

1. Hardened alloy steel components ensure reduced wear and operating damage.
2. Special high pressure seal material and precision machined parts ensure "leak proof" quality.
3. Amtec GX components have successfully operated in the steel industry for over 20 years.

Special features or requirements can be accommodated. Kindly contact your local agent or call our office directly.

Accessories

GR Coupler & GR Nipples

MODELS 641.204.010 / 710.204.010
700 BAR WORKING PRESSURE



Quick disconnect, zinc plated, high-pressure oil connector for use with GR-Nipples exclusively.

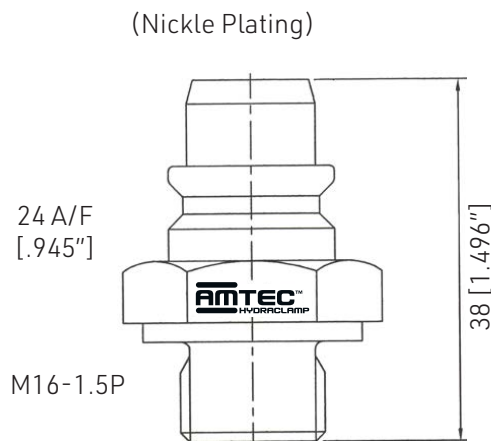

GR-Nipple - 710.204.010

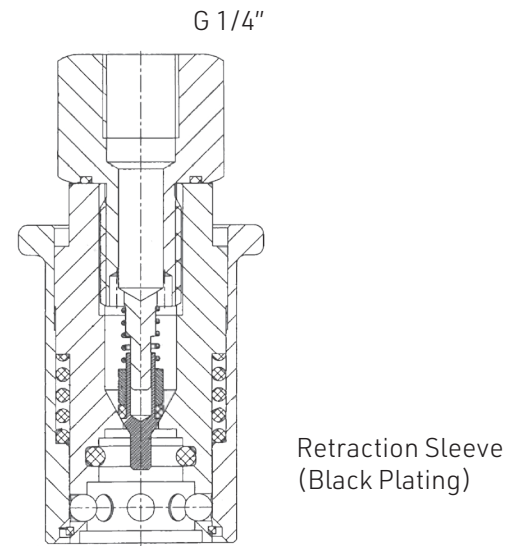

GR-Coupler - 641.204.010

General:

The Amtec Hydraclamp GR-Nipple comes with all double-acting oil-activated clamping systems. The nickel plating differentiates it from the zinc coloured GX-Nipple, and the GR-Nipple is used only for the low-pressure retraction of double-acting clamps.

Safety:

1. Nickel Coating identifies GR-Nipple by sight, while the black oxide retraction sleeve on the GR-Coupler prevents visual mixups.
2. Mechanical interlocks allow only GR components to fully connect before retracting
3. Rated for up to 1,000 bar (14,500 psi) can be handled under special conditions.
4. Compact design allows the GR-Nipple to be fully recessed into the clamping device to prevent operating damage, while the GR Coupler is easily operated with one hand.
5. For high-pressure applications, use the GX system.

Convenience:

1. Pulling back on the black retraction sleeve allows for rapid connection or separation of the GR-Coupler and the GR-Nipple.
2. Low-pressure oil is directed to the clamping device or to the reservoir, depending on operation
3. A ball-type locking arrangement allows for a smooth, positive interlock between the GR-Coupler and the GR-Nipple.

Durability:

1. Hardened alloy steel components ensure reduced wear and operating damage.
2. Special high-pressure seal material and precision machined parts ensure leak proof quality.
3. Amtec GX components have successfully operated in the steel industry for over 20 years.

Special features or requirements can be accommodated. Kindly contact your local agent or call our office directly.

Accessories

Hex Plugs for H-Nuts

Part Number	Description
677.02G09.00001	1/8" G (BSPP) PLUG
677.02G13.00001	1/4" G (BSPP) PLUG
677.02G09.00003	1/8" G (BSPP) STAINLESS PLUG
677.02G13.00003	1/4" G (BSPP) STAINLESS PLUG
677.02M16.00003	M16X1.5 PLUG
677.02M16.00004	M16X1.5 PLUG W/VITON



RH1 Pilot Operated Check Valve

Used with H-450 oil activated hydraulic nuts rated for over 10,000 PSI, this check valve locks hydraulic pressure into our H-Type nuts to provide an extended period of leak-free production.

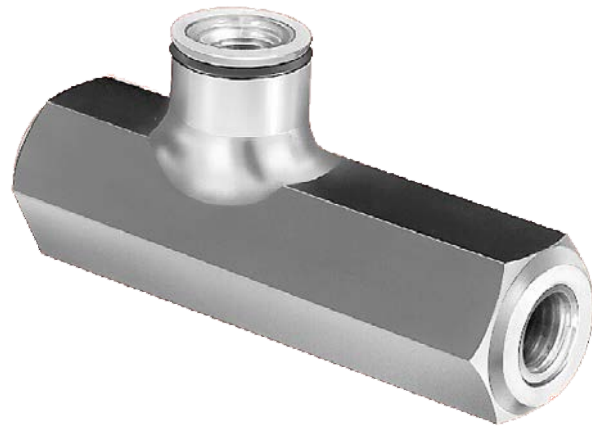

High-Pressure Hose Assemblies

Used with all oil-activated Amtec Nuts, including H-Type and GX-Type.

Standard sizes are available for our oil-type handpumps. Contact your local distributor or Amtec Hydraclamp for more information.



Accessories

Hex Wrenches

381.102.000.010 for K-Nuts

Ratcheting hex wrench set for quick operation of the various hex screws used in Amtec Hydraclamp Hydraulic Nuts.

This set includes 8mm and 10mm extra long hex bits for use with our K-Type Nut actuator assemblies.



Hex wrenches are used on nearly every Amtec Hydraclamp product. The release screw assemblies on F-Type nuts are actuated by 6mm hex wrenches.

The actuator sets on our K-Type nuts use anywhere from 4mm to 10mm hex wrenches, while all K-Type nuts use a 3mm hex wrench for the filler port plug.



Hex Wrenches	
Part Number	Description
381.002.004.010	4mm Hex Wrench
381.002.005.010	5mm Hex Wrench
381.002.006.010	6mm Hex Wrench
381.002.008.013	8mm Hex Wrench
381.002.010.014	10mm Hex Wrench

Hex Wrench Set	
Part Number	Sizes Included in Set
388.101.005.003	3mm and 5mm
388.101.006.003	3mm and 6mm
388.101.006.034	3mm, 4mm and 6mm
388.101.008.003	3mm and 8mm
388.101.008.034	3mm, 4mm and 8mm
388.101.010.003	3mm and 10mm

Standard T-Handle wrenches are also available.

Pressure Transponders

SERIES 550 Pressure Transponders

with PASSIVE RFID Transponder Interface for use with AMTEC HYDRAULIC NUTS.



This series is a unique combination of an extremely sturdy, tried-and-tested industrial pressure transmitter and RFID (radio frequency identification) wireless technology used to accurately measure the setup pressure of Amtec Hydraclamp Hydraulic Clamping Devices.

The Series 550 Transponder provides instant pressure readings using our handheld reader, which is especially important for continuous processes or machines with little dwell time. The reading of pressure does not decay nut pressure, since no gauge or other device needs to be connected to the nut.

Series 550 RFID Passive RFID Pressure Transponders

The plastic cap houses the interface to the pressure transmitter and all RFID components including the antenna. The scanner (sold separately) provides the power required to log instantaneous values.

Performance features

- Extremely resistant to environmental impact
- Ultra-compact stainless steel housing
- High-accuracy, outstanding long-term stability, hysteresis-free
- Temperature displayed alongside accurate pressure reading
- Rated to 1000 bar max pressure capacity
- May be installed into any hydraulic nut or clamp large enough



*SERIES 550RFID
RFID pressure transponder (passive)*

Series 550 RFID

- No auxiliary power supply connector, no internal power source (battery or rechargeable battery)
- Scanners (portable handheld display units or various wired readers) used to read, display and store measurements are also available accessories.

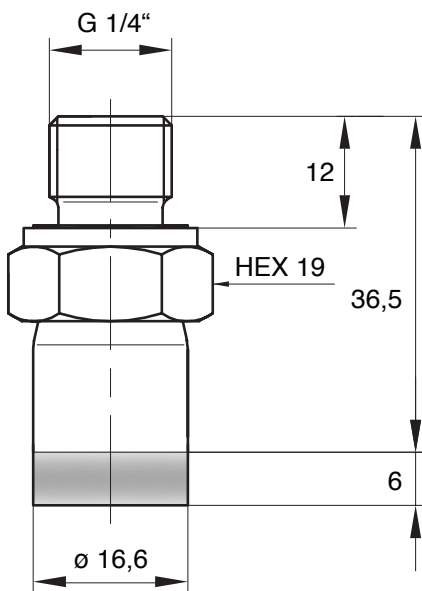



Amtec Hydraclamp
1175 Corporate Dr.
Burlington, ON, PO Box 5011
L7R 3Z4 Canada

Tel: 905-335-8233
Fax: 905-335-6074
inquiries@amtechydraclamp.com
amtechydraclamp.com

2020

© Amtec Hydraclamp